

PIPISTREL



AIRCRAFT MAINTENANCE MANUAL

ALPHA Electro

Document No.: AMM-167-00-60-001

REVISION B02

Date of Issue: August 24, 2021

This is an original document of Pipistrel. Should third-party translations to other languages contain any discrepancies, Pipistrel denies all responsibility. The contents of this manual may not be distributed in any manner (electronically, on the web or printed) without the prior consent of Pipistrel.

Aircraft Maintenance Manual

ALPHA Electro

Authority: Verified and approved under the authority of SLO.DOA.002

Authorized signature: _____

Date of Approval: 24.8.2021

**The airplane must be operated in compliance with
information and limitations contained herein.**

Aircraft Registration Number: _____

Aircraft Serial Number: _____

**For LSA aircraft the two fields above must be filled out with the correct aircraft
registration and serial numbers, or else this manual is rendered invalid.**

Table of contents

GROUP	CHAPTER	SUBJECT
GENERAL		INTRODUCTION
	04-00	AIRWORTHINESS LIMITATIONS
AIRCRAFT	05-00	TIME LIMITS AND MAINTENANCE CHECKS
	06-00	DIMENSIONS AND AREAS
	07-00	LIFTING AND SHORING
	08-00	LEVELING AND WEIGHING
	09-00	TOWING AND TAXIING
	10-00	PARKING, MOORING AND STORAGE
	11-00	REQUIRED PLACARDS
	12-00	SERVICING
	20-00	STANDARD PRACTICES - AIRFRAME
SYSTEMS	21-00	ENVIRONMENTAL SYSTEMS
	24-00	ELECTRICAL POWER
	25-00	EQUIPMENT AND FURNISHING
	27-00	FLIGHT CONTROLS
	31-00	INDICATING/RECORDING SYSTEMS
	32-00	LANDING GEAR
	33-00	LIGHTS
	34-00	NAVIGATION AND PITOT-STATIC SYSTEMS
STRUCTURES	51-00	STANDARD PRACTICES - STRUCTURES
	52-00	DOORS
	53-00	FUSELAGE
	55-00	STABILIZERS
	56-00	WINDOWS
	57-00	WINGS
PROPELLER	61-00	PROPELLER
POWER PLANT	71-00	POWER PLANT
	72-00	ELECTRIC MOTOR
	75-00	POWER PLANT COOLING
	76-00	MOTOR CONTROLS
OTHER	91-00	WIRING DIAGRAMS
	95-00	SPECIAL PURPOSE EQUIPMENT
	99-00	APPENDICES

SCOPE

This ALPHA Electro aircraft maintenance manual (AMM) was prepared by Pipistrel d.o.o. for trained aviation mechanics. It contains a wealth of information about how to successfully clean, inspect, service, remove/install equipment and operationally inspect the ALPHA Electro. It does not, however, contain everything needed to keep the aircraft in airworthy condition. This manual must be used in conjunction with the installation/user/maintenance manuals pertaining to the components/equipment found on the ALPHA Electro. Moreover, all airworthiness directives (AD) issued by the NAA in the country where the aircraft is registered. Lastly, this manual covers the as-delivered configuration and contains very little information regarding part numbers. For ordering information and part numbers please refer to the ALPHA Electro illustrated parts catalogue (IPC).

USING THIS MANUAL

This manual's structure is consistent with the standard chapter numbering system ATA 100. It's chapters also correlate to those listed in ASTM F2483-12, standard practice for maintenance and the development of maintenance manuals for light sport aircraft (see APPENDIX 99-A). The header on each page clearly displays the chapter number and chapter name. The page number and page revision number are displayed in the footer of each page.

The PDF version of this manual enables the user to jump from section to section by clicking on references. Press ALT + LEFT ARROW to return to previous page.

The following warnings, cautions and notes can be found throughout this manual. They provide additional information about particular procedures and makes the owner/operator/mechanic aware of any safety hazards.

WARNING: These provide crucial information about things that may cause bodily harm.

CAUTION: These provide information about things that may component damage.

NOTE: These provide information such as tips and hints that aid the mechanic when carrying out a specific procedure.

Revision tracking, filing and identifying

Pages to be removed or replaced in the Aircraft Maintenance Manual are determined by the log of effective pages located in this section. This log contains the page number and revision number for each page within the AMM. As revisions to the AMM occur, the revision number on the effected pages is updated and the page number in the log is highlighted with bold font type. When two pages display the same page number, the page with the latest revision shall be used in the AMM.

The revision number on the log of effective pages shall also coincide with the revision number of the page in question. As an alternative to removing and/or replacing individual pages, the owner can also print out a whole new manual in its current form, which is always available from www.pipistrel.eu.

Revised material is marked with a vertical bar that extends the full length of deleted, new, or revised text added to new or previously existing pages. This marker will be located adjacent to the applicable text in the marking on the outer side of the page. The same system applies to revised figures, tables and any other elements inside this AMM. A list of revisions is located at the beginning of the log of effective pages. Pipistrel is not responsible for technical changes/updates to OEM manuals supplied with the aircraft (eg. radio, transponder, GPS, etc.).

Index of document revisions

Document revision	Reason for revision	Date issued	Approval reference
B00	Initial issue supersedes AMM-167-0060-001_A00 (12th July, 2017)	January 26, 2018	SLO.DOA.002
B01	Minor changes, definition corrections, corrected figures	October 22, 2020	SLO.DOA.002
B02	Coolant replenishing procedure updated, coolant draining procedure, ELT maintenance, fire safety items, FOD inspection, editorial amendments	August 24, 2021	SLO.DOA.002

List of effective pages

PAGE NUMBER	PAGE REVISION	PAGE NUMBER	PAGE REVISION	PAGE NUMBER	PAGE REVISION	PAGE NUMBER	PAGE REVISION
Cover	-	05-01	-	07-01	-	11-01	-
ii	2	05-02	0	07-02	0	11-02	0
iii	0	05-03	0	07-03	0	11-03	0
iv	1	05-04	1	07-04	0	11-04	0
v	0	05-05	0	07-05	0	11-05	0
vi	2	05-06	0	07-06	0	11-06	0
vii	2	05-07	0	08-01	-	12-01	-
viii	2	05-08	1	08-02	0	12-02	1
ix	2	05-09	1	08-03	0	12-03	0
x	0	05-10	0	08-04	0	12-04	1
xi	1	05-11	0	08-05	0	12-05	1
xii	2	05-12	0	08-06	0	12-06	1
xiii	2	05-13	0	08-07	0	12-07	1
xiv	2	05-14	0	08-08	blank	12-08	1
xv	0	05-15	0	09-01	-	12-09	1
xvi	blank	05-16	0	09-02	0	12-10	1
04-01	-	05-17	0	09-03	0	12-11	1
04-02	0	05-18	0	09-04	0	12-12	blank
04-03	0	05-19	0	09-05	0	20-01	-
04-04	0	05-20	0	09-06	blank	20-02	0
04-05	0	05-21	0	10-01	-	20-03	0
04-06	blank	05-22	0	10-02	0	20-04	0
		05-23	1	10-03	0	20-05	0
		05-24	blank	10-04	1	20-06	0
		06-01	-	10-05	0	20-07	0
		06-02	0	10-06	1	20-08	0
		06-03	0			20-09	0
		06-04	0			20-10	blank
						21-01	-
						21-02	0
						21-03	0
						21-04	0

List of effective pages (continued)

PAGE NUMBER	PAGE REVISION	PAGE NUMBER	PAGE REVISION	PAGE NUMBER	PAGE REVISION	PAGE NUMBER	PAGE REVISION
24-01	-	27-01	-	31-01	-	33-01	-
24-02	0	27-02	0	31-02	0	33-02	0
24-03	0	27-03	0	31-03	0	33-03	0
24-04	0	27-04	0	31-04	1	33-04	0
24-05	0	27-05	0	31-05	1	33-05	0
24-06	0	27-06	0	31-06	0	33-06	0
24-07	0	27-07	0	31-07	0	33-07	0
24-08	0	27-08	0	31-08	blank	33-08	blank
24-09	0	27-09	0				
24-10	0	27-10	0	32-01	-	34-01	-
24-11	0	27-11	0	32-02	0	34-02	0
24-12	blank	27-12	1	32-03	0	34-03	0
		27-13	0	32-04	0	34-04	0
		27-14	0	32-05	0	34-05	0
25-01	-	27-15	0	32-06	0	34-06	0
25-02	0	27-16	0	32-07	0		
25-03	0	27-17	0	32-08	0	51-01	-
25-04	1	27-18	0	32-09	0	51-02	0
25-05	0	27-19	0	32-10	0	51-03	0
25-06	0	27-20	0	32-11	0	51-04	0
25-07	1	27-21	0	32-12	0	51-05	0
25-08	1	27-22	0	32-13	0	51-06	0
25-09	0	27-23	0	32-14	0		
25-10	blank	27-24	0	32-15	0	52-01	-
				32-16	0	52-02	0
				32-17	1	52-03	0
				32-18	0	52-04	0
						52-05	0
						52-06	blank

List of effective pages (continued)

PAGE NUMBER	PAGE REVISION	PAGE NUMBER	PAGE REVISION	PAGE NUMBER	PAGE REVISION	PAGE NUMBER	PAGE REVISION
53-01	-	61-01	-	75-01	-	95-01	-
53-02	0	61-02	0	75-02	0	95-02	0
53-03	1	61-03	0	75-03	0	95-03	1
53-04	1	61-04	0	75-04	0	95-04	0
53-05	0	61-05	0	75-05	0	95-05	0
53-06	0	61-06	blank	75-06	0	95-06	0
55-01	-	71-01	-	75-07	0	99-01	-
55-02	0	71-02	0	75-08	0	99-02	0
55-03	0	71-03	0	75-09	0	99-03	0
55-04	0	71-04	0	75-10	blank	99-04	0
55-05	0	71-05	0	76-01	-	99-05	0
55-06	0	71-06	0	76-02	0	99-06	0
55-07	0	71-07	0	76-03	0	99-07	0
55-08	0	71-08	0	76-04	0	99-08	0
56-01	-	71-09	0	91-01	-	99-09	0
56-02	0	71-10	blank	91-02	0	back cover	-
56-03	0	72-01	-	91-03	0		
56-04	0	72-02	0	91-04	0		
56-05	0	72-03	0	91-05	0		
57-01	-	72-04	0	91-06	0		
57-02	0	72-05	0	91-07	0		
57-03	0	72-06	0	91-08	0		
57-04	0	72-07	0	91-09	0		
57-05	0	72-08	blank	91-10	0		
57-06	0			91-11	0		
57-07	0			91-12	0		
57-08	0			91-13	0		
57-09	0			91-14	blank		
57-10	blank						

PIPISTREL

This page is intentionally left blank.

AIRCRAFT DESCRIPTION

Pipistrel's ALPHA Electro is a 34' 6" (10.5 m) wingspan, two-seat T-tail high-wing motorplane made almost entirely of composite materials. It has a robust, tricycle undercarriage that incorporates brake-equipped wheels, a U-shaped composite strut and a steerable nose wheel. The ALPHA Electro features flaperons that acts both as the flap and the aileron. Flaps offer 3 settings: retracted 0°, +15° and + 25°. Full dual main flight control levers make the ALPHA Electro ideal for initial and advanced flight training. All elevator and flaperon controls are connected to the cabin controls using self-fitting push-pull tubes. The rudder is controlled via cables. The elevator trim is electric. All aircraft ship with H type safety belts attached to the fuselage at three mounting points. The rudder pedals can be adjusted before and also in-flight to suit your size and needs.

The aircraft is equipped with two battery boxes: one is located aft of the cabin bulkhead and the other is forward of the firewall. The battery system is ventilated and thermally protected. The electric motor is a 60 kW peak power unit capable of energy recuperation during descent. The windshield, doors and top window are made of 2 mm anti-UV tinted Lexan, which was specially developed not to shatter or split on impact. The main wheel brakes are hydraulically driven disc type and activated via a cockpit hand-lever. Cabin ventilation is achieved through special vents fitted into the doors.

The propeller is a fixed pitch, three-blade design. The resettable electric circuit breakers enable the pilot to test individual circuit items and disconnect the batteries from the circuit if required. Navigational (NAV) lights, anti-collision (AC) lights and a landing (LDG) light are installed. The firewall is reinforced with heat and noise insulation. Basic instruments come installed with operational limits pre-designated. A BPRS is present and located in aft fuselage.



Figure 01-001
ALPHA Electro

List of abbreviations

Abbreviation	Description
MM	Maintenance manual
OM	Operator's manual
POH	Pilot operating handbook
MLG	Main landing gear
IPC	Illustrated parts catalogue
OEM	Original equipment manufacturer
ELT	Emergency locator transmitter
SB	Service bulletin
SL	Service letter
AD	Airworthiness directives
FH	Flight hours
BPRS	Ballistic Parachute rescue system
LDG	Landing
NAV	Navigation
AC	Anti-collision
FCP	Fast charge port
FOD	Foreign object debris

List of applicable documents

The following is a list of OEM documents that should be on hand whenever the aircraft is being serviced or maintenance procedures are being performed. They're referred to frequently throughout this manual by a number in square brackets.

NOTE: Only the latest version/revision of the documents listed below should be used.

Reference	OEM Document
[1]	Beringer wheel/brake system MM
[2]	Galaxy BPRS installation and users manual
[3]	Applicable Pilot's operating handbook
[4]	FP03-60E Propeller operator's manual
[5]	Kannad ELT 406 AF Compact Operation Manual
[6]	Artex ELT 345 Manual

List of applicable SBs, SIs and ADs

Please refer to your Pipistrel distributor or www.pipistrel-aircraft.com for any/all applicable SBs, SIs and ADs. The owner/operator is required to acquaint themselves, or any maintenance staff, with their content before performing any maintenance procedures.

For additional document applicability information, please refer to:
SB-161-00-80-999 Status of continuing airworthiness documents for ALPHA Trainer LSA and ALPHA Electro LSA aircraft

Safety instructions

Read the following safety instructions carefully before executing maintenance practices.

Accidents/Damage

- Rescue occupant first. Do not move the airplane. Ask for help of personnel familiar with electric airplane.
- Leave the airplane 24h in quarantine after damage occurs before moving it.

Smoke

- If charging, press the “Stop charge” button on the charger immediately.
- Evacuate the vicinity.
- If smoke is observed, stay away from the airplane since batteries may self-ignite.

Battery fire

A clear indication of battery fire is dense smoke and a distinctive chemical smell. Fire can develop quickly and aggressively. Should you encounter battery fire on the ground, react as follows:

- If charging, press the “Stop charge” button on the charger immediately.
- Set MASTER switch OFF.
- Set BATT EN switch OFF.
- Disengage both HV BATT circuit breakers.
- Exit airplane.
- Douse the fire with as much water as possible in order to delay fire propagation.
- Evacuate the vicinity.
- Leave the aircraft 24h in quarantine after damage before moving it.

WARNING: Be aware that lithium battery fires are extremely dangerous because they are self-sustaining! They are a result of a chemical reactions and are impossible to extinguish. You can only prevent or delay fire propagation by continually cooling down the batteries and surrounding items with copious amount of water.

WARNING: DO NOT attempt to restart the motor or to reconnect the batteries after a battery system fire. Aircraft should be under surveillance for at least 24h due to possible latent battery thermal runaway or late cell ignition.

Engine system fire

Should you encounter firewall-forward fire on the ground, react as follows:

- Cut off the Power Lever.
- Set MASTER switch OFF.
- Set BATT EN switch OFF.
- Set PWR EN switch OFF.
- Disengage both HV BATT circuit breakers.
- Disengage PRW CTRL circuit breaker.
- Engage parking brake.
- Exit airplane and evacuate the vicinity.

WARNING: A waterless agent fire extinguisher should be used in case of engine system fire.

WARNING: DO NOT attempt to restart the motor after an engine system fire.

PIPISTREL

This page is intentionally left blank.

04

CHAPTER 04 – AIRWORTHINESS LIMITATIONS

TABLE OF CONTENTS

SECTION	SUBJECT	PAGE NUMBER
04-00	GENERAL Maintenance limitations Structural limitations	04-03

04-00 GENERAL

Chapter 04-00 of this airplane maintenance manual (Airworthiness Limitations) is approved under the authority of SLO.DOA.002. It shows the mandatory limitations that apply to ALPHA Electro and outlines the maximum replacement intervals and/or maintenance requirements for aircraft components, systems, and structures determined to be life limited and/or require monitoring through scheduled maintenance.

Where an interval is given in both flight time and calendar years, the limit that is reached first must be applied.

The time limits given in chapter 04 must be applied to ensure continued airworthiness of the ALPHA Electro.

NOTE: Regular inspections of the airplane including replacement and overhaul of certain components are required to ensure continued airworthiness of the ALPHA Electro.

The following airworthiness limitations and requirements are separated into groups as described below.

Maintenance Limitations - Component and system checks required to be performed during airplane scheduled maintenance.

Structural Limitations – Listing of any limitations associated with the aircraft's structure.

04-00
AIRWORTHINESS
LIMITATIONS

1. Maintenance limitations

The scheduled maintenance requirements listed below must be adhered to:

- **Paint**

Areas exposed to direct sunlight must remain in original white color. No other color is permitted. Only certain areas which are defined in chapter 51-00 of this manual (for example, registration markings, placards and warning markings) may have a different color. The color for registration markings is (grey, red, blue).

- **Paint Finish**

Allowable paint on the wing will have an absorptivity not greater than 0.4, with an emissivity of at least 0.9.

The maximum allowable paint on the fuselage will have an absorptivity not greater than 0.6, with an emissivity of at least 0.7.

2. Structural limitations

The composite airframe structure, cabin, wing, empennage, their carry-through and attaching structure, whose failure would be catastrophic, must be designed to safe life cycle.

Pipistrel ALPHA Electro has been designed and tested for a selected airframe life of 10,000 flight hours with no special structural limitations or inspections.

The structural inspections given in chapter 05-00 cover all required structure checks.

PIPISTREL

This page is intentionally left blank.

05

CHAPTER 05 – TIME LIMITS AND MAINTENANCE CHECKS

TABLE OF CONTENTS

SECTION	SUBJECT	PAGE NUMBER
05-00	GENERAL	05-03
05-10	TIME LIMITS	05-04
05-20	SCHEDULED MAINTENANCE	05-06
05-30	AIRPLANE OPERATIONAL AND FUNCTIONAL CHECK	05-15
05-50	UNSCHEDULED MAINTENANCE	05-16
	Description Maintenance practices	

05-00 GENERAL

It is the aircraft owner's responsibility to keep the ALPHA Electro in good, airworthy condition at all times and this chapter provides information on how to do it. It covers topics such as recommended intervals for the overhaul/replacement of components, scheduled/unscheduled maintenance for the ALPHA Electro and general maintenance hints/tips. The time intervals mentioned in this chapter are those recommended by the manufacturer, Pipistrel d.o.o , and should be considered the minimum required to keep the airplane in good operating condition.

It should be noted, however, that the NAA in the country where the aircraft is registered may have different requirements regarding time limits and maintenance checks. Its requirements must be adhered to at all times, including any directives or bulletins it issues. The requirements found in this manual DO NOT override those of the NAA.

All of the intervals and checks outlined in this manual were established based on test data taken in moderate conditions on grass runways. If the aircraft is operated in extreme conditions, such as those with drastically high/low temperatures, sandy environments and/or air with a higher than normal salt content, shortening the recommended intervals is advisable.

CAUTION: The NAA of the country where the aircraft is registered may, if deemed necessary, choose to shorten and/or lengthen the time limit/inspection intervals in this chapter. The aircraft owner/operator is required to acquaint themselves with NAA alterations/changes before maintaining/servicing the aircraft.

NOTE: Pipistrel reserves the right to change the contents of this manual, including maintenance intervals, and all/any changes will be published in the form of a revision.

05-10
TIME LIMITS

05-10 TIME LIMITS

Certain components installed on the ALPHA Electro have time limits which dictate when they're supposed to be overhauled or replaced. This chapter provides information about these limits. Pipistrel recommends the following items be overhauled or replaced at the following intervals or "On Condition" (O/C). O/C items must be overhauled or replaced when, upon inspection, it's determined that they're faulty, have incurred damage, are unserviceable or in bad condition.

CAUTION: All of the time limits outlined in Table 05-001 must be considered when performing the 100 hour/Annual inspection. Removal or overhaul of any these items must be entered into the aircraft technical log book.

CAUTION: If a components time limit is to occur before the next planned inspection, it must be included in the current inspection.

NOTE: The limits mentioned in Table 05-001 DO NOT indicate product lifetime and must not be interpreted as such.

Item No.	Description	Interval		Maintenance		Notes/Reference
		HRS	YRS	OH	RPLC	
1	Beringer wheel assembly	1000*	10*	X**		*Whichever comes first ** See maintenance procedures in [1]
2	Beringer brake assembly	2500*	5*	X**		*Whichever comes first ** See maintenance procedures in [1]
3	Beringer wheel assembly	10000*	20*	X**		*Whichever comes first ** See overhaul procedure in [1]
4	Beringer brake assembly	10000*	20*	X**		*Whichever comes first ** See overhaul procedure in [1]
5	Standard wheel/brake assembly - tires		5		X*	See 32-00
6	Standard wheel/brake assembly - brake lines	10000			X	See 32-00
7	Hydraulic brake oil		5		X	See 32-40 and 12-10
8	ELT battery	1*			X	* After one hour of real transmission or before/on the battery expiration date. [5] [6]
9	ELT system		6*			* Various tests, inspection and replacements. [5] [6]
10	Propeller assembly	1000		X		To be performed by Pipistrel or Pipistrel-authorized mechanic
11	Coolant pump	2000	5		X*	*Whichever comes first. Remove and send to Pipistrel. See 75-00
12	Electric motor bearings	2000			X*	Remove and send to Pipistrel. See 72-00

Item No.	Description	Interval		Maintenance		Notes/Reference
		HRS	YRS	OH	RPLC	
13	Coolant		5		X	Or if the motor is replaced or overhauled
14	Nose gear shock absorber	2000			X	See 32-20
15	Rubber coolant hoses		5		X	See 75-00
16	GRS ballistic parachute rescue system		6*			*Rescue system needs to be removed and sent to OEM for repacking. See 95-00
17	Motor mount rubber isolators		5		X	See 71-20
18	GRS ballistic parachute rescue system		30		X	*Rescue system needs to be removed, sent to OEM and replaced. See 95-00
19	Batteries	*	*		X	*Replace when SOH<10%
20	Junction box	6000		X		Remove and send to Pipistrel. See 24-60: 2.11

Table 05-001
ALPHA Electro Time Limits

NOTE: The aircraft owner/operator and/or the person maintaining/servicing the aircraft is required to acquaint themselves with and implement the time limits listed in the various maintenance manuals referred to in Table 05-001.

05-20
SCHEDULED
MAINTENANCE**05-20 SCHEDULED MAINTENANCE**

The inspection schedule outlined in this chapter is what the manufacturer of the ALPHA Electro, Pipistrel d.o.o , regards as the minimum, in order to keep the aircraft in airworthy condition. The owner/operator is responsible for keeping the aircraft in airworthy condition and shall use this chapter as a guide. It is not, however, by any means the only guide that should be used. The NAA airworthiness directives in the country the aircraft is registered in MUST be adhered to, as well as those issued by EASA. Maintenance/service personnel is chosen by the aircraft owner/operator and thus it is also his/her responsibility to ensure they are qualified.

CAUTION: The owner/operator must give any personnel carrying out maintenance/servicing procedures on the aircraft access to records of any past maintenance, as well as all of the aircraft's documentation.

VISUAL INSPECTION

The most common task found in the ALPHA Electro's inspection schedule is the visual inspection. This is essentially an inspection to determine the general state of a component and typically does not require disassembly/removal of any other assemblies/equipment nearby. It is to be performed according to the following criteria and with any/all aids deemed necessary:

Metal Parts – discolouration due to heat exposure, distortion, wear/cracks due to fatigue, corrosion, weld damage, cleanliness and any other forms of damage.

Moving Components – Proper and unhindered operation, alignment, sufficient sealing, cleanliness, sufficient lubrication, travel, general condition, fastening material secured, signs of excessive wear, cracking, corrosion, deformation, and any other forms of damage.

Air, and Oil Lines – Kinks, deterioration, chafing, poor flexibility, obstruction, bend radius, cleanliness, sufficiently secured/fastened and any other forms of damage.

Fastening Material - corrosion, wear, damage, loosening (paint marker) and safety wiring intact.

Composite Components – general condition, cleanliness, deformation, dents, warpage, cracks, scratches and any other forms of damage/wear. Composite surfaces that are bare, therefore, not painted, can also be checked for signs of delamination, fluid saturation and wear.

NOTE: If any composite component damage is found, a tap test should be performed to determine how extensive it is. Refer to 51-10 for additional guidelines on how to properly perform a visual inspection and/or tap test on composite components.

Electrical Installations - loose, corroded, or broken terminals/connectors; chafed, broken, or worn insulation; fastening material intact, heat deterioration, deformation, hardening, and any other forms of damage.

Filters and Screens - contamination, obstructions, signs of wear/damage.

Areas with Liquids - Evidence of leaks, sealant condition, signs of bacteria growth, cleanliness, corrosion, delamination, separation of bond, and structural fatigue.

OPERATIONAL INSPECTION

The second most common task found in the ALPHA Electro's inspection schedule is the operational inspection. This is essentially an inspection to determine whether the component/part/assembly functions properly and does what it's supposed to do. Operational inspections of control surfaces must include a positive check, which is where one person holds the control surface steady, while the other moves the flight controls in both directions. This check confirms that movement of the flight controls results in movement of the control surface.

NOTE: It is expected that whenever a specific part or component is inspected, the inspection will include observation and evaluation of the component's surrounding area.

SCHEDULED MAINTENANCE PROGRAMS AND REQUIREMENTS

All airplanes of EU registry must undergo a complete "a 100 Hour Inspection Program" each 12 calendar months and additional requirements of the NAA of the country where the airplane is registered.

The 100 Hour Inspection Program is required, in addition to a complete Annual Inspection, for all airplanes of EU registry.

Inspection Program Intervals

Annual Inspection Time Intervals

The inspection interval to the next Annual Inspection may not exceed twelve calendar months. For Example: If an inspection were signed off on 14 June 2005, the next Annual Inspection would be due and must be accomplished no later than 29 June 2006. All subsequent Annual Inspections will be due in June unless the schedule is reset by performing an Annual Inspection early.

100 Hour Inspection Time Intervals

The interval between 100 Hour Inspections should never be exceeded by more than 10 hours, and then only if additional time is required to reach a place where the inspection can be satisfactorily accomplished. Additionally, the time the interval was exceeded must be included as flight hours in the next interval. For example: If a 100 Hour Inspection was due at 650 flight hours and was actually signed-off at 658 flight hours, the next 100 Hour Inspection is due at 750 flight hours, not 758 flight hours. Inspection tolerances cannot be accumulated.

Airplane Operational and Functional Checks

Operational and Functional Checks must be performed before and after Scheduled Maintenance Inspections to detect any airplane abnormalities or malfunctions. These inspections are listed in chapter 05-30, Airplane Operational and Functional Checks. (See 05-30).

Unscheduled Maintenance Checks

Abnormal airplane operations require special maintenance checks. Definitions and inspection procedures for hard/overweight landings, exceeded speed limit, severe air turbulence, lightning strike, high drag/side loads due to ground handling, and ground gusts are listed in chapter 05-50, Unscheduled Maintenance Checks.

SCHEDULED INSPECTION REPORT

All references to “05-20” under the “ATA Ref” reference column are to be understood as reference to Visual Inspection criteria defined above under Inspection Groups and Criteria.

Recommended Overhaul and Replacement Times

Recommended overhaul and replacement times are listed in chapter 05-10, Time Limits. These maintenance items must be incorporated into the 100 Hour or Annual Inspections as applicable.

Special Inspections

Special Inspections are highlighted in red and always denoted with a bracketed asterisk [*]. Those special inspections beginning with the word “And” indicate that the special inspection is to be performed IN ADDITION TO the regularly scheduled interval. For example, the following inspection states that in addition to inspecting the tail skid every 50 Hours, it should also be changed after the first 25 hours of operation as well.

Fuselage and Empennage Group	ATA Ref	50 Hr	Annual/ 100 Hr
Tail skid - Visual inspection. *Special Inspection: And after first 25 hours	05-20	[x]	[]

If the special inspection includes the word “Only”, this means that the it’s to be performed ONLY at the specified time interval. For example, the following inspection states that the battery box Inspection/Check should only be performed every 500 hours or every 5 years, whichever occurs first.

Cabin Group	ATA Ref	50 Hr	Annual/ 100 Hr
Battery box - Visual inspection. *Special Inspection: Only every 500 hours or 5 years whichever first.	24-30: 2.1.	[]	[]

Major Inspections

Major Inspections are also highlighted in red and accompanied by the word “and” or “only” (see Special Inspections). They are thorough, in-depth inspections that determine whether or not the load-bearing components have incurred any wear/damage that may affect the airworthiness of the aircraft.

Foreign Object Debris (FOD)

Minimize/eliminate FOD in and around any aircraft during maintenance practices, as it can cause damage and possibly injure personnel. Airplane houses high voltage batteries/installations, that are susceptible to short circuits due to misplaced/dropped nuts, bolts, washers, etc. That is why an inspection for FOD must be performed after the completion of all/any maintenance procedures mentioned in this manual.

WARNING: After any maintenance procedure mentioned in this manual has been performed, a FOD inspection must be carried out in order to minimize/eliminate FOD.

Scheduled Inspection Report			
Make: PIPISTREL ALPHA Electro	Model: 167	Serial Number:	Registration Number:
Owner:	Date:	Place:	
Type of Inspection: [] 50 Hour [] 100 Hour	[] Annual [] 200 Hour [] 500 Hour [] 1000 Hour [] 10000 Hour	Operating Time: Flight Hours: Landings:	

Item No.	Pre-Inspection	ATA Ref	50 Hr	Annual/ 100 Hr	200 Hr	500 Hr	1000 Hr	10000 Hr
1	Wash and clean the aircraft fully (external and internal)	12-20: 2.6.	[]	[x]	[]	[]	[]	[]
2	Operational/Functional Check Perform an airplane run-up in accordance with Operational Check in 05-30. Record of all abnormalities during the inspection. After completing the Operational Check, perform a walk around to detect fluid leaks or other abnormalities.	05-30	[]	[x]	[]	[]	[]	[]
3	Review compliance status with current / NAA Aviation Regulations. This includes inspection of the following: - Aircraft Log Book - Registration Certificate - Certificate of Airworthiness - Weight and Balance Record - NAA Airworthiness Directives - ALPHA Electro Design Service Documents - POH	-	[]	[x]	[]	[]	[]	[]

05-20
SCHEDULED
MAINTENANCE

Item No.	Firewall Forward Group	ATA Ref	50 Hr	Annual/ 100 Hr	200 Hr	500 Hr	1000 Hr	10000 Hr
1	Electric motor - Visual inspection.	24-30 71-00	[]	[X]	[]	[]	[]	[]
2	Motor Cowling - Visual Inspection and operational inspection of charging port door.	05-20 71-10	[]	[X]	[]	[]	[]	[]
3	Foam baffling/seals - Visual Inspection, replace if necessary	05-20 71-00	[]	[X]	[]	[]	[]	[]
4	Junction box - Perform inspection/check *Special Inspection: And after first 100 hours	05-20 24-60: 2.1.3.	[]	[]	[]	[X]	[]	[]
5	Fast charge port and cables - Visual inspection	05-20	[]	[X]	[]	[]	[]	[]
6	Motor mount and mounting fixture - Perform inspections/checks	71-10: 2.1.1.	[]	[X]	[]	[]	[]	[]
7	Firewall - Visual Inspection	53-30	[]	[]	[]	[]	[X]	[]
8	Power controller - Perform inspection/check *Special Inspection: after the first 100 hours and every 2000 hours	71-00: 2.2.3.	[]	[]	[]	[]	[*]	[]
9	Cooling system pump - Visual inspection	05-20	[]	[X]	[]	[]	[]	[]
10	Cooling system hoses - Visual inspection	05-20	[]	[X]	[]	[]	[]	[]
11	Cooling system cooler - Visual inspection	05-20	[]	[X]	[]	[]	[]	[]
12	Cooling system expansion tank - Visual inspection	05-20	[]	[X]	[]	[]	[]	[]
13	Cooling system overflow bottle - Visual inspection	05-20	[]	[X]	[]	[]	[]	[]
14	Power cables and electrical harnesses - Visual inspection	71-50	[]	[X]	[]	[]	[]	[]

Item No.	Battery Group	ATA Ref	50 Hr	Annual/ 100 Hr	200 Hr	500 Hr	1000 Hr	10000 Hr
1	Aft and fore battery box - Visual inspection	24-30	[]	[X]	[]	[]	[]	[]
2	Battery power/ data cables Visual inspection	24-30	[]	[X]	[]	[]	[]	[]

Item No.	Cabin Group	ATA Ref	50 Hr	Annual/ 100 Hr	200 Hr	500 Hr	1000 Hr	10000 Hr
1	Cabin windows and windshield - Visual Inspection for cracking, crazing, and general condition. Perform inspections/checks	05-20 56-00	[]	[x]	[]	[]	[]	[]
2	Magnetic Compass - Visual Inspection	05-20	[]	[x]	[]	[]	[]	[]
3	Placards and Instrument Markings - Visual Inspection for conformity, security, and condition. Replace if necessary.	05-20 11-20	[]	[x]	[]	[]	[]	[]
4	Upholstery - Visual Inspection	05-20	[]	[]	[]	[x]	[]	[]
5	Seats Visual and operational inspection	05-20	[]	[x]	[]	[]	[]	[]
6	Safety harnesses Visual and operational inspection	05-20	[]	[x]	[]	[]	[]	[]
7	Instrument Panel Visual Inspection	05-20	[]	[x]	[]	[]	[]	[]
8	Avionics + Switch panel Visual and operational inspection	31-10: 2.1.	[]	[]	[x]	[]	[]	[]
9	Control stick + control stick drive - Perform inspections/checks *Major Inspection: Only every 3000 Hr (see 27-30: 2.4.2. and 27-30: 2.5.2.).	27-30: 2.4.1. 27-50: 2.5.1.	[]	[x]	[]	[]	[]	[]
10	Wiring behind the instrument and switch panel – Remove instrument panel cover and perform visual inspection for any loose/damaged wires	05-20 31-10	[]	[]	[]	[x]	[]	[]
11	Rudder Control System - Perform inspections/checks	27-20: 2.1.3. 27-20: 2.3.	[]	[x]	[]	[]	[]	[]
12	Brake actuation hand lever - Visual and operational Inspection	05-20	[]	[]	[x]	[]	[]	[]
13	Flexible Brake Hoses - Visual Inspection -	05-20	[]	[]	[x]	[]	[]	[]
14	Cabin Doors - Perform inspection/check	52-10: 2.1.3.	[]	[x]	[]	[]	[]	[]
15	Rudder Control System - Perform inspections/checks	27-20: 2.1.2.	[]	[]	[x]	[]	[]	[]
16	GRS ballistic parachute rescue system activation handle - Perform inspection/check	95-00: 2.1.1.	[]	[]	[]	[x]	[]	[]
17	ELT - Visual inspection	05-20	[]	[]	[x]	[]	[]	[]
18	ELT - *Special Inspection in accordance with NAA: Only every 24 months or earlier if required by NAA where the aircraft is registered, contact NAA	-	[]	[]	[]	[]	[]	[]

05-20
SCHEDULED
MAINTENANCE

Item No.	Cabin Group	ATA Ref	50 Hr	Annual/ 100 Hr	200 Hr	500 Hr	1000 Hr	10000 Hr
19	Transponder - *Special Inspection in accordance with NAA: Only every 24 months or earlier if required by NAA where the aircraft is registered. Contact NAA	-	[]	[]	[]	[]	[]	[]
20	Flaperon control system - Perform inspections/checks *Major Inspection: Only every 3000 FH (see 27-50: 2.4.2.).	27-50	[]	[]	[x]	[]	[]	[]
21	Brake system hydraulic fluid Check and replenish if necessary	12-20: 2.5.	[]	[x]	[]	[]	[]	[]
22	Cabin floor - Perform inspection/check + tap test	53-20: 2.11.	[]	[]	[]	[x]	[]	[]
23	Elevator control system - Perform inspections/checks *Major Inspection: Only every 3000 FH (see 27-30: 2.2.2.).	27-30: 2.2.1.	[]	[]	[x]	[]	[]	[]
24	Power lever - Visual and operational inspection	05-20	[]	[x]	[]	[]	[]	[]
25	Power lever - Perform inspection/check	76-00: 2.11.	[]	[]	[x]	[]	[]	[]

Item No.	Fuselage and Empennage Group	ATA Ref	50 Hr	Annual/ 100 Hr	200 Hr	500 Hr	1000 Hr	10000 Hr
1	Exterior Placards Visual Inspection for conformity, security, and condition. Replace if necessary.	05-20 11-10	[]	[X]	[]	[]	[]	[]
2	Fuselage skin/shell - Perform inspection/check + major bonding lines tap test *Major Inspection: Only every 2000 FH (see 53-10: 2.1.)	53-10: 2.1. 51-10: 2.2.	[]	[X]	[]	[]	[]	[]
3	GRS ballistic parachute rescue system - Visual Inspection of hatch and rocket exhaust hole	05-20	[]	[X]	[]	[]	[]	[]
4	Vertical Stabilizer and Rudder Surfaces – Visual Inspection + vertical stabilizer major bonding line tap test	05-20 51-10: 2.2.	[]	[X]	[]	[]	[]	[]
5	Rudder Control System – Perform inspections/checks.	27-20: 2.1.1. **	[]	[X]	[]	[]	[]	[]
6	Rudder Control System – Perform inspections/checks	27-20: 2.1.1. 27-20: 2.4.1. 27-20: 2.4.1.	[]	[]	[X]	[]	[]	[]
7	Horizontal Stabilizer and Elevator Surfaces - Visual Inspection + horizontal stabilizer major bonding line tap test	05-20 51-10: 2.2.	[]	[X]	[]	[]	[]	[]
8	Horizontal Stabilizer and Elevator Surfaces - Perform inspection/check	55-20: 2.1.3.	[]	[]	[X]	[]	[]	[]
9	Vertical/horizontal stabilizer – Perform inspections/checks	55-30: 2.1.1. 55-10: 2.1.3.	[]	[X]	[]	[]	[]	[]
10	Vertical stabilizer – Perform inspections/checks + tap test	55-10: 2.1.3.	[]	[]	[]	[X]	[]	[]
11	Elevator Control System Perform inspections/checks	27-30: 2.4. 27-30: 2.5.	[]	[X]	[]	[]	[]	[]
12	Elevator Control System Perform inspections/checks *Major Inspection: Only every 2000 FH (see 27-30: 2.6.2.)	27-30	[]	[]	[X]	[]	[]	[]
13	Fuselage Vent/Drain Holes Visual Inspection for obstructions or blockage.	APPENDIX 99-B	[]	[X]	[]	[]	[]	[]
14	Antennas - Visual inspection	05-20	[]	[X]	[]	[]	[]	[]
15	Aft battery bay bulkhead - Visual Inspection of composite around safety harness attachment points	05-20	[]	[]	[]	[X]	[]	[]
16	Control Surface and Stabilizer Vent/Drain Holes - Visual Inspection for obstructions or blockage.	APPENDIX 99-B	[]	[]	[X]	[]	[]	[]
17	At and fore battery bay - Visual inspection + tap test	05-20 51-10	[]	[X]	[]	[]	[]	[]
18	At and fore battery bay door - Check that cooling scoop/outlet not blocked/dirty	05-20	[]	[X]	[]	[]	[]	[]

**perform without removing the rudder (2.1.1.3) for the 100-hour check, just move rudder to one side and inspect/check. Perform with rudder removed every 200 hours.

05-20
SCHEDULED
MAINTENANCE

Item No.	Wing Group	ATA Ref	50 Hr	Annual/ 100 Hr	200 Hr	500 Hr	1000 Hr	10000 Hr
1	Wing surface - Visual Inspection for general condition, deterioration, delamination, distortion, cracks, paint condition, and other evidence of failure. *Major Inspection: Only every 2000 FH (see 57-10: 2.1.3.).	05-20	[]	[X]	[]	[]	[]	[]
2	Wing Leading Edge Visual Inspection for foreign matter and debris + leading edge bonding line tap test	05-20 51-10: 2.2.	[]	[X]	[]	[]	[]	[]
3	Flaperon Surfaces - Visual Inspection	05-20	[]	[X]	[]	[]	[]	[]
4	Flaperon system free play- Perform inspection/check	27-50: 2.1.3. 27-30: 2.1.4.	[]	[]	[X]	[]	[]	[]
5	Flaperon surfaces- Perform inspection/check	57-50: 2.1.2.	[]	[]	[X]	[]	[]	[]
6	Pitot tube - Visual inspection	05-20	[]	[X]	[]	[]	[]	[]
7	Wing Vent/Drain Holes - Visual Inspection for obstructions or blockage.	APPENDIX 99-C	[]	[X]	[]	[]	[]	[]

Item No.	Landing Gear Group	ATA Ref	50 Hr	Annual/ 100 Hr	200 Hr	500 Hr	1000 Hr	10000 Hr
1	Main Landing Gear Fairings - Visual inspection	05-20	[]	[X]	[]	[]	[]	[]
2	Nose Landing Gear Fairing - Visual inspection	05-20	[]	[X]	[]	[]	[]	[]
3	Tires - Visual inspection and check/replenish tire pressure	05-20 12-10: 2.2.	[]	[X]	[]	[]	[]	[]
4	Brake pads and discs - Perform inspection/check	32-42: 2.2. 32-42: 2.3.	[]	[X]	[]	[]	[]	[]
5	Brake lines - Visual Inspection	05-20	[]	[X]	[]	[]	[]	[]
6	Wheels - Visual Inspection	05-20	[]	[X]	[]	[]	[]	[]
7	Nose gear - Perform Inspection/Check	32-20: 2.2.1.	[]	[X]	[]	[]	[]	[]
8	Main landing gear strut - Perform inspection/check.	32-10	[]	[X]	[]	[]	[]	[]
9	Brake actuation lever - Visual inspection	05-20	[]	[X]	[]	[]	[]	[]

05-30 AIRPLANE OPERATIONAL AND FUNCTIONAL CHECK

The following check must be performed before and after the Scheduled Maintenance Inspection to detect any airplane abnormalities or malfunctions. A portion of the check is accomplished with the motor running and warmed up.

WARNING: In order to perform the following check, the motor must be operating. Do not stand or let anyone else stand close to the arc of the airplane's propeller while conducting this check.

CAUTION: During all motor running operations outlined in this check, exercise caution to avoid harm or damage to personnel and equipment due to propeller blast and rotating propeller blades.

CAUTION: Excessive motor, electrical system and batteries temperatures must be avoided.

Item No.	Operational Inspection Report	Check	Notes
1	Flight Controls Check for full range of travel and excessive friction. Visual Inspection for obstructions.		
2	Motor Control Check full range of throttle motion without any obstruction or excessive friction to travel.		
3	MASTER switch + AVIONICS switch When switches are toggled ON the following should occur: — EPSI570 Display turns on and runs with no indication of any errors. — EPSI570, FLIGHT page: both battery status turns READY — All Kanardia instruments turn on, perform self-check and run with no indication of any errors. — Trim position indicator turns on.		
4	POWER Switch When POWER switch is toggled on the following should occur: — EPSI570, SYSTEM page: both battery status turns ACTIVE. — "click-clack" noise identifies battery release closed.		
5	THROTTLE Switch When THROTTLE switch is toggled on the following should occur: — Propeller oscillates shortly and then stops.		
6	Motor (parking brake activated) — Set motor power to 65 kW. — Check EPSI570 FLIGHT page: all green or black. — Check EPSI570 SYSTEM page: both battery status ACTIVE and battery voltage within the range. — Check that brakes hold aircraft stationary at full power with no slipping. CAUTION: depending on wheels/brakes installed and airplane weight, the braking force may not be sufficient to hold the airplane during full power ground test. — Set throttle to idle, propeller should come to a complete stop immediately. — Shut down - switch toggled OFF (see dedicate chapter in "[3]" on page xiii).		

05-50
UNSCHEDULED
MAINTENANCE

05-50 UNSCHEDULED MAINTENANCE

1. Description

The following describes those maintenance checks and inspections on the aircraft which are dictated by special or unusual conditions which are not related to the time limits specified in 05-10, Scheduled Maintenance Checks.

These includes inspections and checks for wing strike, hard/overweight landing, exceeded speed limit, severe air turbulence, lightning strike, high drag/side loads, ground gusts, operation in harsh environmental conditions, and operation on unimproved runway surfaces.

2. Maintenance practices

05-50: 2.1. Wing strike

05-50: 2.1.1. Fuselage

Step	Action	Required parts, materials and tools	Reference
1	Aft Floor Structure – Area around and under the wing attach points and overhead seat areas, inspect for delamination, cracking, whitening, and any other evidence of structural damage.		53-00

05-50: 2.2. Propeller strike

05-50: 2.2.1. Propeller

Step	Action	Required parts, materials and tools	Reference
1	Check blades for signs of damage. In case of strike with rotating propeller an overhaul is necessary.		61-00

05-50: 2.3. Hard landing

NOTE: A hard landing is any landing made at what is believed to be an excessive sink rate. An overweight landing is defined as landing the airplane at any gross weight which exceeds the maximum take-off weight as specified in the Pilot’s Operating Handbook. If the hard/overweight landing is combined with high drag/side loads, additional checks are required.

05-50: 2.3.1. Fuselage

Step	Action	Required parts, materials and tools	Reference
1	Aft Floor Structure – Inspect for delamination, cracking, whitening, and any other evidence of structural damage.		53-00
2	Main landing gear strut - Inspect for security of attachment, permanent deformation, delamination, and cracking or splintering of strut.		32-10: 2.1.2.
3	Main gear attachments and supporting structure - Inspect for security loose or failed fasteners, permanent deformation, damage to fairings, tire damage, and any other evidence of structural damage.		
4	Nose gear and attaching structure - Inspect for security, loose or failed fasteners, permanent deformation of strut or axle, strut weld cracks, puck delamination and cracks, puck pan weld cracks, motor mount weld cracks, damage to fairing, tire damage, and any other evidence of structural damage.		32-00
5	Wings surface - Inspect for skin cracks, loose of failed fasteners, and any evidence of structural damage.		57-00
6	Trailing edge - Inspect for any deformation effecting normal flaperon operation.		27-00
7	Fore and aft battery compartment - tap test - inspect for structural damage to the floor, sidewalls, and retaining battery holes.		51-10: 2.2.
8	Check EPSI 570 for waring messages.		APPENDIX 99-C

05-50: 2.4. Exceeded speed limit

An exceeded speed limit inspection must be performed anytime the airplane has exceeded one or both of the following:

- exceeding placard speed limits of flaps.
- exceeding design speeds.
- exceeding rpm speed of propeller and of the motor /motor

05-50
UNSCHEDULED
MAINTENANCE

05-50: 2.4.1. Fuselage

Step	Action	Required parts, materials and tools	Reference
1	Landing gear - Main gear axle and fittings - Inspect for cracks, security, and evidence of structural damage. Tires - Inspect tires for flat spots, excessive wear, and tire slippage on the wheel rim.		32-00
2	Fuselage - Windshield and windows - Inspect for buckling, dents, loose or failed fasteners, and any evidence of structural damage.		56-00 52-00
3	Cowling - Inspect for buckling, cracks, loose or failed fasteners, and indications of structural damage.		71-10
4	Stabilizers - Inspect skins, hinges and attachments, movable surfaces, mass balance weights, and attaching structure for cracks, dents, buckling, loose or failed fasteners, and evidence of structural damage.		55-00
5	Wings - Flaps - Inspect for skin buckling, cracks, loose or failed fasteners, attachments and structural damage.		57-00 27-00

05-50: 2.4.2. Propeller and motor

Step	Action	Required parts, materials and tools	Reference
1	Motor: Speed limit for the motor is 4500 rpm. In the unlikely event of exceeding this speed, remove/send the motor to the manufacturer to be inspected/overhauled.		71-00
2	Propeller: speed limit of the propeller is 2575 rpm. If this speed is exceeded for more than 20 seconds, remove/send the motor to the manufacturer to be inspected.		61-10: 2.1.

05-50: 2.5. Severe turbulence and/or maneuvers

Atmospheric conditions producing violent buffeting of airplane. Severe maneuvers can be defined as any maneuvers exceeding the Pilot's Operating Handbook and the airplane's flight limits.

Step	Action	Required parts, materials and tools	Reference
1	Horizontal stabilizer, hinge fittings, and fittings - Inspect for security, loose or failed fasteners, and any evidence of structural damage.		27-00 55-00
2	Vertical stabilizer - Inspect for evidence of structural damage, and damage to hinges and fittings.		27-00 55-00
3	Elevator and rudder balance weight supporting structure - Inspect for security, loose or failed fasteners, and evidence of structural damage.		27-00 55-00
4	Wing to body fittings and supporting structure - Inspect for security, loose or failed fasteners, and evidence of structural damage.		53-00 57-00
5	Wing trailing Edge - Inspect for and deformation affecting normal operation of flap and aileron.		27-00 57-00
6	Fore and aft battery compartment - inspect for structural damage to the floor, sidewalls, and retaining battery holes.		53-00

05-50: 2.6. Lightning strike

If flown through a region of the atmosphere where electrical discharge is occurring, the airplane may become part of the discharge path. During a lightning strike, the current enters the airplane at one point and exits another, usually at opposite extremities. It is in these entrance and exit points where damage is most likely to occur. Burning and/or eroding of small surface areas of the skin and structure may be detected during inspection. In most cases, the damage is obvious. In some cases, however, hidden damage may result. In the case of lightning strike, this inspection must be accomplished before returning it to service.

05-50: 2.6.1. Communications

Step	Action	Required parts, materials and tools	Reference
1	Antennas - Inspect all antennas for evidence of burning or eroding. If damage is noted, call PIPISTREL for disposition. Any component connected to the antenna may need to be returned to manufacturer for servicing.		34-00

05-50
UNSCHEDULED
MAINTENANCE

05-50: 2.6.2. Navigation

Step	Action	Required parts, materials and tools	Reference
1	Compass should be considered serviceable if the corrected heading is within plus or minus 10 degrees of heading indicated by the remote compass system. If remote compass is not within tolerance, remove, repair, or replace.		

05-50: 2.6.3. Fuselage

Step	Action	Required parts, materials and tools	Reference
1	Skin - Inspect surface of fuselage skin for evidence of damage.		53-00

05-50: 2.6.4. Stabilizers

Step	Action	Required parts, materials and tools	Reference
1	Inspect surfaces of stabilizers for evidence of damage.		55-00

05-50: 2.6.5. Wings

Step	Action	Required parts, materials and tools	Reference
1	Skin - Inspect for evidence of burning and eroding.		57-00
2	Wing tips - Inspect for evidence of burning and pitting.		
3	Flight surfaces and hinging mechanisms - Inspect for burning and pitting.		

05-50: 2.6.6. Landing gear/wheels

Step	Action	Required parts, materials and tools	Reference
1	Landing gear attach fittings and axles - Inspect for evidence of pitting and damage.		32-00
2	Wheels - Inspect for evidence of pitting and damage.		
3	Wheel pants and fairings - Inspect fasteners for pitting and damage.		
4	Brake lines - Inspect for evidence of pitting, damage, or hydraulic fluid leaks.		

05-50: 2.6.7. Propeller

Step	Action	Required parts, materials and tools	Reference
1	Propeller - Inspect surfaces of blades for evidence of damage. If damage is noted, remove from service and have inspected by Pipistrel or Pipistrel-authorized mechanic.		05-20

05-50: 2.6.8. Power plant and electrical systems

Step	Action	Required parts, materials and tools	Reference
1	Perform visual inspection of propulsion system (i.e. firewall forward components, battery boxes, electrical harnesses/cables). Consult with Pipistrel		05-20

05-50: 2.7. High drag/side loads due to ground handling

A high drag/side load condition is defined as situations when the airplane skids or overruns from a prepared surface onto an unprepared surface. This condition can also be met due to landings short of prepared surfaces, landings which cause the blowing of tires, or skidding conditions where the safety of the airplane was in question. This covers takeoffs, landings, or unusual taxi conditions.

05-50: 2.7.1. Landing gear

Step	Action	Required parts, materials and tools	Reference
1	Main gear and fairings - Inspect for loose or failed fasteners, buckling, security, cracks, and evidence of structural damage.		32-00
2	Nose gear and fairing - Inspect for loose or failed fasteners, cracks, security, buckling, and evidence of structural damage.		

05-50: 2.7.2. Wings

Step	Action	Required parts, materials and tools	Reference
1	Wing to fuselage fittings and attaching structure - Inspect for security, loose or failed fasteners, and evidence of structural failure.		57-00

05-50: 2.8. Ground gusts

Ground gusts are defined as conditions where a parked or taxiing airplane is exposed to side, aft quartering, or aft wind gusts exceeding 40 knots. Such conditions can cause control system damage due to rapid oscillation and/or slamming of the control surfaces against system stops.

05-50: 2.8.1. Rudder

Step	Action	Required parts, materials and tools	Reference
1	Hinges - Inspect for loose or failed fasteners, deformation, cracks, evidence of structural damage, and for any other evidence of damage or premature wear.		27-00 55-00

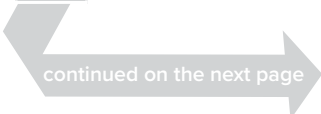

05-50
UNSCHEDULED
MAINTENANCE

Step	Action	Required parts, materials and tools	Reference
2	Attaching structure - Inspect for loose or failed fasteners, delaminating, cracks, evidence of structural damage, punctures, scratches, and for any other evidence of damage or premature wear.		
3	Skin - Inspect for buckling, dents, misalignment, punctures, scratches, and for any other evidence of damage or premature wear.		
4	Attaching hardware - Inspect for loose or failed fasteners, deformation, cracks, security of mass balance weights, balance weight supporting structure and for any other evidence of damage or premature wear.		
5	Bellcrank - Inspect for failed fasteners, cracks and deformation.		

05-50: 2.8.2. Elevator

Step	Action	Required parts, materials and tools	Reference
1	Hinges - Inspect for loose or failed fasteners, deformation, cracks, evidence of structural damage, and for any other evidence of damage or premature wear.		27-00 55-00
2	Attaching structure - Inspect for loose or failed fasteners, delaminating, cracks, evidence of structural damage, punctures, scratches, and for any other evidence of damage or premature wear.		
3	Skin - Inspect for buckling, dents, misalignment, punctures, scratches, and for any other evidence of damage or premature wear.		
4	Bellcrank - Inspect for failed fasteners, cracks and deformation.		

05-50: 2.8.3. Flaperons

Step	Action	Required parts, materials and tools	Reference
1	Hinges - Inspect for loose or failed fasteners, deformation, cracks, evidence of structural damage, and for any other evidence of damage or premature wear.		27-00
2	Attaching structure - Inspect for loose or failed fasteners, delaminating, cracks, evidence of structural damage, punctures, scratches, and for any other evidence of damage or premature wear.		
3	Skin - Inspect for buckling, dents, misalignment, punctures, scratches, and for any other evidence of damage or premature wear.		

05-50: 2.9. Operation on unimproved runway surfaces

Operation on unimproved runway surfaces will cause additional wear and may require additional maintenance or inspection.

05-50: 2.10. Operation in humid areas

In humid areas, special care should be taken to keep motor , accessories, and airframe clean to prevent oxidation. Visually inspect flight control surfaces, nose landing gear and control systems for corrosion in accordance with best aviation maintenance practice.

05-50: 2.11. Power plant component overheating

The power plant components have been designed to ensure proper temperature regulation in most operational and environmental conditions. The system incorporates certain high-temperature features that monitor/manage component temperatures and thus reduce the chances of overheating occurring. If, however, a power plant component overheats, it must be removed and sent to Pipistrel to be inspected.

05-50: 2.12. Post battery fire scenario Post crash (even without immediate fire development) scenario

In the event of battery fire scenario (after the fire has been extinguished) or after aircraft crash (without no immediate fire development) there is a risk of battery cells igniting or exploding even after several hours after the event has occurred.

In both cases, 24h quarantine of the aircraft is required:

- aircraft must be left on its location in open space (not in hangar)
- properly secured, no approach within 10 m from aircraft
- no maintenance task should be performed before 24h

PIPISTREL

This page is intentionally left blank.

06

CHAPTER 06- DIMENSIONS AND AREAS

TABLE OF CONTENTS

SECTION	SUBJECT	PAGE NUMBER
06-00	GENERAL Airplane dimensions and areas Control surface travel and deflection angles	06-03

06-00 GENERAL

This chapter outlines the basic dimensions/areas of the ALPHA Electro and the control surface travel/deflections.

1. Airplane dimensions and areas

Basic Dimensions	Metric	Imperial
Length	6,47 m	21,23 ft
Span	10,50 m	34,45 ft
Height	2,05 m	6,73 ft
Wing		
Area	9,29 m ²	99,99 ft ²
Span	10,50 m	34,45 ft
Mean wing chord	0,900 m	2,95 ft
Horizontal Tail		
Area	1,08 m ²	11,63 ft ²
Vertical Tail		
Area	1,10 m ²	11,84 ft ²

06-00
DIMENSIONS AND AREAS



Figure 06-001
ALPHA Electro three view drawing

2. Control surface travel and deflection angles

Please refer to the latest revision of ALPHA Electro's weight and balance report (WBR 167-08-10-001) for all control surface travel and deflection angle data.

07

CHAPTER 07 – LIFTING AND SHORING

TABLE OF CONTENTS

SECTION	SUBJECT	PAGE NUMBER
07-00	LIFTING AND SHORING General	07- 03
07-10	JACKING Description Maintenance Practices	07- 04
07-20	SHORING Description Maintenance Practices	07- 06

07-00 GENERAL

This chapter covers the materials and procedures that apply to lifting and shoring the ALPHA Electro. The procedures outlined in this chapter mainly apply to situations where the aircrafts landing gear needs to be attended to, serviced and/or removed.

07-10
JACKING

07-10 JACKING

1. Description

Particular maintenance procedures require propping certain parts of the aircraft up. Removing the main landing gear wheel, for example, requires propping up the landing gear strut. Removing the nose landing gear wheel, on the other hand, requires propping up the front end of the aircraft. A description of how to carry this out and the materials needed is outlined in this chapter.

2. Maintenance Practices

07-10: 2.1. Main landing gear strut

NOTE: Two people are required to carry out this procedure.

07-10: 2.1.1. Propping up one side

Step	Action	Required parts, materials and tools	Reference
1	Position the aircraft on a surface that is flat and hard.	- Landing gear stand (P/N 1190264) - Torx screwdriver set - T-handle hex head screwdriver set	
2	Remove the main wheel fairing.		see 32-10
3	Lift the wing.		Figure 07-001
4	Place landing gear stand under landing gear strut.		Figure 07-002
5	Slowly lower wing so that the landing gear strut rests on the stand.		



Figure 07-001
Lifting the wing



Figure 07-002
Landing gear stand placement

NOTE: If necessary, the landing gear strut can be propped up on both sides using the same stand and following the same procedure as outlined above.

07-10: 2.2. Nose landing gear

07-10: 2.2.1. Propping up

Step	Action	Required parts, materials and tools	Reference
1	Position the aircraft on a surface that is flat and hard.	- tail cone counterweight (oblong bean bag)	Figure 07-003
2	Slowly place counterweight on tail cone.		

CAUTION: Position the aircraft so it's front end is clear of all other objects. Make sure the propeller and/or cowlings won't hit anything when the front end is propped up.



Figure 07-003
Tail cone counterweight

07-20
SHORING

07-20 SHORING

1. Description

Shoring/hoisting the aircraft is only necessary in a few instances, such as when the landing gear has failed or the aircraft's fuselage is badly damaged. This chapter describes the equipment needed and procedure that needs to be followed in order to shore/hoist the aircraft.

2. Maintenance Practice

07-20: 2.1. Hoisting the fuselage

CAUTION: Before lifting/hoisting the airframe always clear the immediate area of people and equipment.

07-20: 2.1.1. Hoisting the fuselage

Reference:

Step	Action	Required parts, materials and tools	Reference
1	Remove the main wheel fairings.	- Hoisting rod set	see 32-10
2	Remove the wings.		see 57-10
3	Slide both hoisting rods through the fuselage's cabin support strut assembly and secure them so they can't shift or move.		
4	Use chains or some heavy-duty nylon straps to fasten the hoisting rods to a crane or hoist.		
5	Use the crane/hoist to slowly lift the airframe from it's position. Adjust the hoisting rods, straps or chains if necessary.		
6	Prop the airframe up with some padded trestles.		

08

CHAPTER 08 – LEVELING AND WEIGHING

TABLE OF CONTENTS

SECTION	SUBJECT	PAGE NUMBER
08-00	GENERAL	08-03
08-10	LEVELING	08-04
	Description Maintenance Practices	
08-20	WEIGHING	08-05
	Description Maintenance Practices	

08-00 GENERAL

This chapter provides all the information needed to level and weigh the airplane properly. If the aircraft is not operated in the right center of gravity envelope, flight performance and safety may be compromised. The ALPHA Electro must be weighed and the center of gravity calculated/checked every time a modification is carried out that could affect these characteristics.

08-10
LEVELING

08-10 LEVELING

1. Description

This chapter describes how to level the airplane for any maintenance procedures which may be necessary.

2. Maintenance practices

08-10: 2.1. Leveling

08-10: 2.1.1. Leveling the airplane

Reference: POH-167-00-40-050

Step	Action	Required parts, materials and tools	Reference
1	Inflate tires.	- aircraft leveling kit (P/N 1190460)	12-10
2	Prop up starboard MLG wheel by pulling the port wing down and place MLG balance block under wheel. Do the same for the port MLG wheel by lifting the port wing.		
3	Prop up nose wheel by weighing down the tail cone. Place nose wheel wedge under wheel.		
4	Fit the tail cone with the leveling tool and place spirit level on it.		Figure 08-001
5	Adjust nose wheel wedge until the spirit level reads 0°.		



Figure 08-001
Leveling tool and spirit level setup

NOTE: Please see [3] for alternative leveling method if leveling tool is not available.

08-20 WEIGHING

1. Description

This chapter describes how to properly weigh the ALPHA Electro. Expected flight performance and safety can only be achieved if the ALPHA Electro is operated in the approved center of gravity envelope. If the aircraft is modified in any way, the center of gravity and weight must be recalculated and verified as acceptable.

2. Maintenance practices

08-20: 2.1. Weighing

08-20: 2.1.1. Preparation

Reference: POH-167-00-40-050

Step	Action	Required parts, materials and tools	Reference
1	Replenish the brake fluid reservoir.	- three scales (one with minimum scale capacity of 250 kg, two with 500 kg)	12-10
2	Close the doors and set the flaps to 0°.		
3	Check/verify equipment list.		
4	Level aircraft and place a scale under each of the MLG balance blocks and the nose wheel wedge.		08-10

Note: The two scales used under the MLG wheels must be equal in height and placed as outboard as possible.

08-20: 2.1.2 Measuring

Reference: POH-167-00-40-050,

Step	Action	Required parts, materials and tools	Reference
1	Drop a plump bob from datum (each wing root leading edge at root) and stretch a line between the plump bobs and mark the position of the line at the airplane center line.	- plump bob - string - measuring tape	Figure 08-002
2	Stretch a line between the main wheel centers and mark the position of the line at the airplane center line.		Figure 08-003

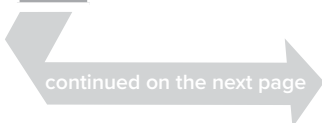

08-20
WEIGHING

Step	Action	Required parts, materials and tools	Reference
3	Measure the distance between the position of the wing root leading edge and the position of the MLG wheel centers horizontally along the airplane center line. Obtain value 'b'.		
4	Measure the distance between the position of the wing root leading edge and the position of the nose wheel center horizontally along the airplane center line. Obtain value 'a'.		Figure 08-004
5	Remove the level/leveling fixture and record the weight values show on the scales.		



Figure 08-002
Plumb bob from wing leading edge



Figure 08-003
Plum bob from center of the MLG wheels

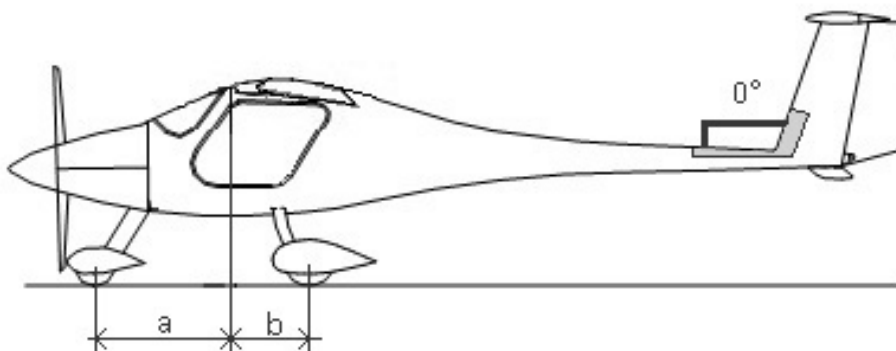

Figure 08-004
Weight and Balance measurements

NOTE: For center of gravity calculation see ALPHA Electro's weight and balance report (WBR 167-08-10-001).

PIPISTREL

This page is intentionally left blank.

09

CHAPTER 09 – TOWING AND TAXIING

TABLE OF CONTENTS

SECTION	SUBJECT	PAGE NUMBER
09-00	GENERAL	09-03
09-10	TOWING Description Maintenance Practices	09-04
09-20	TAXIING Description Maintenance Practices	09-05

09-00 GENERAL

This chapter describes how to properly tow and taxi the ALPHA Electro along the ground.

09-10
TOWING

09-10 TOWING

1. Description

One person can easily tow the ALPHA Electro by him/herself along smooth, hard terrain by pulling/pushing it. Turning is made easier by propping up the front end of the aircraft while simultaneously pushing/pulling it. The following procedures describe how to properly tow the ALPHA Electro.

2. Maintenance practices

CAUTION: Never push or pull the aircraft using its control surfaces.

09-10: 2.1. Towing

09-10: 2.1.1. Backwards

Step	Action	Required parts, materials and tools	Reference
1	Remove wheel chocks.		
2	Check that there is nothing obstructing the way or any hazards in the vicinity.		
3	Push the aircraft backwards using the point halfway up the vertical stabilizers as a push point.		
4	Place wheel chocks under wheels.		

09-10: 2.1.2. Forwards

Step	Action	Required parts, materials and tools	Reference
1	Remove wheel chocks.		
2	Check that there is nothing obstructing the way or any hazards in the vicinity.		
3	Push the aircraft forwards using the point on the fuselage halfway between the wing's trailing edge and the vertical stabilizer as a push point.		
4	Place wheel chocks under wheels.		

09-10: 2.1.3. Turning

Step	Action	Required parts, materials and tools	Reference
1	Check that there is nothing obstructing the way or any hazards in the vicinity.		
2	Prop the front end of the aircraft up slightly by pushing down on the tail cone while simultaneously pushing the aircraft in the desired direction.		

09-20 TAXIING

1. Description

This chapter provides instructions necessary to taxi the ALPHA Electro. The thrust needed to taxi it is supplied by the propeller, while turning/steering is done by foot pressure on the rudder pedals. The immediate area around the aircraft must be inspected for any obstructions/safety hazards and cleared if necessary.

2. Maintenance practices

09-20: 2.1. Taxiing

CAUTION: Excessive braking can lead to worn brake pads/discs. The area must be cleared of all/any personnel before taxiing ensues. All potholes and rough terrain should be avoided if possible. Refer to the POH for all other procedures/checks pertaining to taxiing.

09-20: 2.1.1. Taxiing the airplane

Reference: POH-167-00-40-050

Step	Action	Required parts, materials and tools	Reference
1	Remove wheel chocks.		
2	Perform motor start-up procedure.		see [3]
3	Gradually throttle up until taxiing ensues and then immediately check that the brakes work.		
4	Taxi the aircraft to the desired location.		
5	Shut the aircraft down.		see [3]
6	Place wheel chocks under wheels.		

PIPISTREL

This page is intentionally left blank.

10

CHAPTER 10 – PARKING, MOORING AND STORAGE

TABLE OF CONTENTS

SECTION	SUBJECT	PAGE NUMBER
10-00	GENERAL	10-03
10-10	PARKING	10-04
	Description Maintenance Practices	
10-20	MOORING	10-05
	Description Maintenance Practices	
10-30	STORAGE	10-06
	Description Maintenance Practices	

10-00 GENERAL

This chapter describes how to park, moor and store the ALPHA Electro properly. Mooring is typically required when the aircraft is left outside for longer periods of time and may be exposed to windy conditions. The recommended storage measures outlined in this chapter should be implemented in order to prevent wear/deterioration of the ALPHA Electro's structure/systems.

**10-10
PARKING**

10-10 PARKING

1. Description

This chapter describes how to park the ALPHA Electro properly. It outlines measures that should be for long term parking and parking in abnormal conditions.

2. Maintenance Practice

10-10: 2.1. Parking

10-10: 2.1.1. Temporary (< 10 days)

Reference: chapter 7 of [3]

Step	Action	Required parts, materials and tools	Reference
1	Come to a complete stop	- wheel chocks	
2	Perform motor shut-down		see [3]
3	Insert BPRS activation handle safety pin		
4	Engage parking brake		
5	Exit the aircraft and place wheel chocks under wheels.		
6	Close all the cabins windows/openings if wet weather is expected.		
7	Moor the aircraft if windy weather is expected.		see 10-20

10-10: 2.1.2. Long term (> 10 days)

Follow the same procedure outlined above for temporary parking, however, consider the storage measures outlined in 10-30.

10-20 MOORING

1. Description

This chapter describes how to moor the ALPHA Electro properly. Each wing has a fixed mooring point built into its bottom surface. The tail skid has a hole that can be used as the third tie down point. These points can be used to fasten the aircraft to the ground.

2. Maintenance Practice

10-20: 1.1. Mooring

10-20: 1.1.1. Mooring the airplane

Reference:

Step	Action	Required parts, materials and tools	Reference
1	Park the aircraft.	- wheel chocks - mooring rings (P/N 1190014) - tie down straps (synthetic)	see 10-10
2	Retract the flaps fully.		
3	Remove the mooring point caps.		
4	Install the mooring rings.		
5	Run tie down straps through the rings and secure them to the ground.		
6	Run a tie down strap through the tail skid hole and secure it to the ground.		

NOTE: Refer to chapter 10-30 for additional storage measures/procedures.

10-30
STORAGE

10-30 STORAGE

1. Description

This chapter describes all of the measures necessary to store the airplane for temporary or long-term storage.

2. Maintenance practices

10-30: 2.1. Storage

10-30: 2.1.1. Temporary storage (10-60 days)

Step	Action	Required parts, materials and tools	Reference
1	Park the aircraft on a dry, level surface that is not exposed to sunlight, but do not engage parking brake.		10-10
2	Moor if necessary.		10-20
3	Cover the pitot tube.		
4	Check main and nose landing gear tire pressure on a weekly basis and replenish if necessary.		12-10
5	Turn each wheel by a quarter turn once a week to avoid warping/damage.		
6	Disconnect the battery boxes and consider all maintenance and shelf-life measures recommended by the battery manufacturer.		24-30: 2.1.3.
7	Clean all aircraft surfaces and remove bugs/dirt.		
8	Clean entire propeller and remove bugs/dirt.		
9	Cover windshield and sunroof with a cotton sheet.		
10	Follow all required battery storage/charging procedures in POH.		[3]

CAUTION: If the wings must be disassembled (see 57-10) due to hangar space limitations, store them in a dry, cool space with no sunlight, and covered with a cotton sheet.

10-30: 2.1.2. Long term storage (> 60 days)

Step	Action	Required parts, materials and tools	Reference
1	Perform temporary storage procedure, rest charge procedure (storage charge, once every 90 day) and consult Pipistrel distributor.		

11

CHAPTER 11 – REQUIRED PLACARDS

TABLE OF CONTENTS

SECTION	SUBJECT	PAGE NUMBER
11-00	GENERAL	11-03
11-10	EXTERIOR PLACARDS	11-04
	Description Maintenance Practices	
10-20	INTERIOR PLACARDS	11-07
	Description Maintenance Practices	

11-00 GENERAL

There are various placards located throughout the ALPHA Electro that provide pilots, occupants and first responders with very important information. They identify safety precautions, provide service instructions, indicated command direction/movements and provide operating instructions.

11-10
EXTERIOR PLACARDS

11-10 EXTERIOR PLACARDS

1. Description

This chapter describes the maintenance practices which apply to those placards located on the exterior of the ALPHA Electro 167.

11-10: 1.1. Placards (External)

Exterior placard illustrations are available in Chapter 3 of [3]

2. Maintenance Practice

11-10: 2.1. Exterior Placard

11-10: 2.1.1. Removal

Step	Action	Required parts, materials and tools	Reference
1	Peel placard away from surface. If it doesn't peel away easily, apply heat with heat gun and try again.	- heat gun	
CAUTION: Be careful when using the heat gun. Do not allow the surface temperature to exceed 54°C (129° F), as this may cause structural damage.			
2	Once removed, clean the surface with pure acetone to remove residual adhesive.	- acetone (pure)	see 20-30

11-10: 2.1.2. Installation

Follow the same procedure outlined above for temporary parking, however, consider the storage measures outlined in 10-30.

Step	Action	Required parts, materials and tools	Reference
1	Wash/wipe the surface down with water and clean white cotton cloth.	- water - acetone (pure) - clean white cotton cloth - paper towel	see 20-30
2	Clean the surface with pure acetone.		
3	Allow to air dry.		
4	Remove placard from protective foil.		
5	Apply placard to surface. Avoid creating wrinkles by applying one edge of the placard first and then running your finger along it until it's completely adhered.		

11-20 INTERIOR PLACARDS

1. Description

This chapter describes the maintenance practices which apply to those placards located on the interior of the ALPHA Electro.

11-20: 1.3. Placards (Interior)

Interior placard illustrations are available in Chapter 3 of [3].

2. Maintenance Practice

11-20: 2.1. Interior Placard

11-20: 2.1.1. Removal

Step	Action	Required parts, materials and tools	Reference
1	Peel placard 11-05 away from surface. If it doesn't peel away easily, apply heat with heat gun and try again.	- heat gun	
CAUTION: Be careful when using the heat gun. Do not allow the surface temperature to exceed 54°C (129° F), as this may cause structural damage.			
2	Once removed, clean the surface with pure acetone to remove residual adhesive.	- acetone (pure)	see 20-30

11-20: 2.1.2. Installation on non-composite and/or paint-coated composite surfaces

Step	Action	Required parts, materials and tools	Reference
1	Wash/wipe the surface down with water and clean white cotton cloth.	- water	
2	Clean the surface with pure acetone.	- acetone (pure)	see 20-30
3	Allow to air dry.	- clean white cotton cloth	
4	Remove placard from protective foil.	- paper towel	
5	Apply placard to surface. Avoid creating wrinkles by applying one edge of the placard first and then running your finger along it until it's completely adhered.		

11-20
INTERIOR PLACARDS

11-20: 2.1.3. Installation on bare composite surfaces

Step	Action	Required parts, materials and tools	Reference
1	Clean the surface with pure acetone.	- acetone (pure) - paper towel - spray glue (Extra strong, Tesa)	see 20-30
2	Allow to air dry.		
3	Remove placard from protective foil.		
4	Spray some glue on the back surface of the placard and apply it to the surface. Avoid creating wrinkles by applying one edge of the placard first and then running your finger along it until it's completely adhered.		

12

CHAPTER 12 – SERVICING

TABLE OF CONTENTS

SECTION	SUBJECT	PAGE NUMBER
12-00	GENERAL	12-03
12-10	REPLENISHING	12-04
	Description Maintenance Practices	
12-20	SCHEDULED SERVICING	12-08
	Description Maintenance Practices	

12-00 GENERAL

This chapter clearly outlines all of the procedures/practices involved in properly servicing the ALPHA Electro. Procedures such as lubricating various components and keeping the aircraft clean, are key to ensuring the aircraft remains in good condition, safe and airworthy.

The maintenance/servicing intervals specified in chapter 05-00 are those recommended by Pipistrel and shall be considered adequate in normal operating conditions. If the aircraft is operated in abnormal conditions, such as salt water environments, extremely humid areas and dusty environments, or if it's operated any unusual conditions, it shall be considered prudent to shorten the intervals in chapter 05-00.

CAUTION: Not adhering to the warning and cautions outlined in this chapter can cause damage to the aircraft, harm to the aircrafts operator and possibly harm to others. Only those operating fluids mentioned in this manual are permitted to be used. Mixing various fluids, using non-recommended brands or using contaminated fluids is not permitted and can lead to aircraft damage or harm to its operators/occupants.

12-10
REPLENISHING

12-10 REPLENISHING

1. Description

This chapter outlines the maintenance procedures that pertain to replenishing the ALPHA Electro's operating fluids. For servicing intervals refer to chapter 05-00. Table 12-001 contains information about approved operating fluids and their capacity.

Description	P/N or Spec.	Capacity
Propulsion system coolant	%50 antifreeze %50 water	1 L two-part solution

NOTE: This is the total quantity of fully emptied system. Upon draining procedure, some amount of the coolant remains in the system. Therefore, upon replenishing, the amount of replenished coolant is expected to be less than total capacity of the system, unless the system was fully emptied (i.e. vacuumed or disassembled).

Brakes	DOT 4 Hydraulic Fluid	0,20L
Beringer Nose Tire (Size 4.00 X 4")	Dry Compressed Air	1,5 bar
Beringer MLG Tires (Size 4.00 X 6")	Dry Compressed Air	2,5 bar
Pipistrel Nose Tire 4,00" x 4"	Dry Compressed Air	1,5 bar
Pipistrel MLG Tires 4,00" x 6"	Dry Compressed Air	2,5 bar

Table 12-001
Approved operating fluids and capacities

2. Maintenance practices

12-10: 2.1. Engine cooling system

12-10: 2.1.1. Replenishing the coolant

Step	Action	Required parts, materials and tools	Reference
<p>WARNING: Do not replenish the coolant when the motor is still hot after operation. Wait for it to cool down!</p>		<ul style="list-style-type: none"> - approved coolant, see 12-10 - replenishing cap (p/n 1288203) - cooling system bleeding pump (p/n 5620065) - measuring bucket (p/n 5251001) 	71-10: 2.1.1.
1	Remove the cowlings.		
2	Cut the zip tie securing the transparent silicon water hose attached to the expansion tank overflow port and remove the hose.		
3	Replace the expansion tank cap with the replenishing cap.		
4	Connect a vacuum pump with a hose to the overflow port on the expansion tank through a T-port ball valve. Submerge the other hose (equipped with valve) from the T-port ball valve into a measuring bucket filled with coolant.		Figure 12-001 Figure 12-002

NOTE: Make sure that measuring bucket is filled with sufficient amount of coolant. Fill it with more than 1L to prevent unlikely suction of the air at the end.



Figure 12-001
Hose connected to the expansion tank overflow port through a ball valve.

5	Make sure the valve on the hose submerged in coolant is closed and the valve on the hose connected to vacuum pump is opened.
6	Start the vacuum pump and suck the air out of the engine cooling system.
<p>NOTE: Recommended vacuum range (- 0.8 bar to - 0.9 bar).</p>	
7	Close the vacuum pump line on the T-port ball valve and open the valve on the line submerged in coolant.
8	Let the vacuum suck the coolant into the engine cooling system.

12-10
REPLENISHING

Step	Action	Required parts, materials and tools	Reference
------	--------	-------------------------------------	-----------



Figure 12-002
Vacuum pump hose connected to the overflow port of the expansion tank through a T-port ball valve while the other hose, also equipped with ball valve is submerged into the measuring bucket.

9	Repeat steps from 5 to 8.		
10	Close the valve on the hose submerged to coolant and start the cooling system pump. The coolant will mix with remaining air.		
11	With the coolant pump running, open the valve on the hose connected to vacuum pump and apply low pressure vacuum to the overflow port and slowly suck out the remaining air.		
	Repeat the purging process outlined in step 11 until the coolant becomes free of air bubbles. Indications of a completely purged system are:		
12	<ul style="list-style-type: none"> -less and less air will be removed from the system with every purge, until the last purge results in only fluid being removed. -the vacuum pump will keep getting quieter with each purge. 		
	(The whole process takes about 20 min)		

NOTE: During purging process, the level of coolant in expansion tank can drop due to purged air bubbles. The cooling system is fully replenished when:

- the system is completely purged.
- expansion tank is full.
- the level of coolant in the overflow bottle must be between min and max.

NOTE: If coolant was drained out before, the minimum volume of replenished coolant should match the measured volume of the drained liquid.

Table 12-001
12-20: 2.3.1.

13	Shut down the cooling system pump and disconnect the vacuum pump.		
14	Remove the replenishing cap and make sure that expansion tank is full.		
15	Replace the replenishing cap with the expansion tank cap.		
16	Connect the transparent silicon water hose to the expansion tank overflow port and secure it with a zip tie.		
17	Install the cowlings.		

71-10: 2.1.2.

12-10: 2.2. Tires

12-10: 2.2.1. Check/replenish tire air pressure

Reference: chapter 2 in [3]

Step	Action	Required parts, materials and tools	Reference
1	Remove tire pressure inspection plug from wheel fairing.	- compressed air - pressure gauge (P/N 5610132)	Table 12-001
2	Roll aircraft a backwards or forwards a little until the tire's valve stem lines up with the opening in the fairing.		
3	Remove tire valve cap.		
4	Measure tire air pressure.		
5	Replenish if necessary with compressed air to the required pressure.		
6	Release pressure from the tire if it is already overinflated.		
7	Install tire valve cap.		
8	Install tire pressure inspection plug.		

12-10: 2.3. Brakes

32-42: 2.3.1. Replenishing the brake fluid

Reference:

Step	Action	Required parts, materials and tools	Reference
1	Open the brake fluid reservoir lid, by releasing the two screws on the top. Pull the brake handle to reach the aft screw with the screw driver.	- Philips screw drivers set - Meter or measuring tape - Plastic cups	12-10
2	Using a plastic cup, pour the brake fluid into the brake reservoir. Check the fluid level, and fill till the level is 10 mm measured from the reservoir top edge.		
3	Close the brake reservoir lid.		
4	Bleed the brake system and perform a operational test.		

3. Battery System

The ALPHA Electro incorporates two battery boxes, one fore of the cabin and one aft cabin. Please see chapter 2 in [3] for a detailed description of how to charge them.

12-20
SCHEDULED SERVICING

12-20 SCHEDULED SERVICING

1. Description

This chapter describes the regular servicing requirements of the ALPHA Electro. Systems and components such as coolant, the brakes and the tires, need be serviced regularly in order to keep the aircraft in good operating condition. How to clean the aircraft and its various components/assemblies is also covered.

2. Maintenance practices

12-20: 2.3. Cooling system

12-20: 2.3.1. Draining the system

Reference:

Step	Action	Required parts, materials and tools	Reference
1	Remove cowlings.	-measuring bucket (p/n 5251001)	71-10: 2.1.1.
2	Remove aft and fore battery box.		24-30: 2.1.1.
3	Release or cut the hoses connected to cooler.		
CAUTION: All hoses removed from barbed fittings must be replaced by new ones.			
4	Remove hose clamps.		
5	Drain the liquid into drain pan.		
NOTE: If only removing the water pump, it is not necessary to cut the hose connected to expansion tank. Just cut hose leading to pump and drain.			
NOTE: Measure the quantity of drained liquid by decanting it into measuring bucket. Measured quantity must match the minimum volume of the liquid to be replenished into the system.			Table 12-001 12-10: 2.1.1.
6	Install aft and fore battery box.		24-30: 2.1.2.
7	Install cowlings.		71-10: 2.1.2.

12-20: 2.4. Landing gear

Tire and wheel servicing procedures are covered in 12-10: 2.2. Refer to 32-41 for tire and wheel removal instructions.

12-20: 2.4.1. Draining the brake lines

Reference:

Step	Action	Required parts, materials and tools	Reference
1	Place a cup or a container below each brake pad.	- Philips screw drivers set - Plastic cups	
2	Disconnect the brake line quick fittings from the brake pads and place the line ends into the cups.		
3	Enter the cabin and open the brake fluid reservoir lid, by releasing the two screws on the top. Pull the brake handle to reach the aft screw with the screw driver.		
4	Collect the brake fluid that will flow out the brake lines into the cups.		

12-20: 2.5. Lubrication

The ALPHA Electro has a number of components and assemblies that must be kept well lubricated in order to avoid premature wear, deterioration and possible seizing. The table below, Table 12-002, shall be used as a lubrication guide. It clearly indicates what needs to be lubricated, how often and what it should be lubricated with. All the joints in Table 12-002 must be cleaned first with some paper towel before fresh lubricant is applied.

Group	Component	Interval (hrs)	Recommended lubricant
Cabin	All rod end bearings accessible from the cabin floor control stick openings	100	Wurth HHS Lube
Cabin	Control stick drive end bearings	100	Wurth HHS Lube
Cabin	All rod end bearings located between the cabin and aft battery bay bulkheads	200	Wurth HHS Lube
Fuselage	Door hinges	100	Wurth white assembly paste
Fuselage	Elevator hinge pins	200*	SKF LGMT 2/0.2 multipurpose grease
Fuselage	Upper rudder hinge pin	200*	Wurth white assembly paste
Fuselage	Upper rudder bushing	200*	Wurth white assembly paste
Fuselage	Horizontal stabilizer T-fixation plate pins	100	Wurth white assembly paste
Fuselage	Horizontal stabilizer att. bolt assembly	100	Wurth white assembly paste
Fuselage	Vertical stabilizer bushings	100	Wurth white assembly paste
Fuselage	Rudder cable bellcrank	200	Wurth white assembly paste
Fuselage	Wing shear pin bushings	200*	Wurth white assembly paste
Fuselage	Upper flaperon bellcrank clutch	200	Wurth white assembly paste
Fuselage	Vertical elevator push rod end bearings and aft horizontal elevator push rod end bearing	200	Wurth HHS Lube
Wings	Flaperon pins/bushings	200*	SKF LGMT 2/0.2 multipurpose grease
Wings	Wings spar pins	200	SKF LGMT 2/0.2 multipurpose grease
Wings	Shear pins	200*	Wurth white assembly paste
Wings	Wing spar bushings	200	SKF LGMT 2/0.2 multipurpose grease

*Shortening service interval is recommended for all aircraft that operate in unusual/abnormal environments (i.e. high humidity, salt water, dusty conditions, extreme temperatures, etc.).

Table 12-002
Lubrication guide

12-20
SCHEDULED SERVICING**12-20: 2.6. Cleaning**

In order for the ALPHA Electro to perform the way it should, all of the airframe's surfaces must be cleaned on a regular basis. This is especially true for the wing's leading edges, which can seriously affect performance if left dirty. Cleaning must be carried out carefully, so that the aircraft's composite surfaces don't incur any damage.

CAUTION: Rubbing any of the aircraft's surfaces aggressively or polishing any of them is not permitted and, if necessary, can only be carried out by an approved maintenance organization.

CAUTION: Avoid the use of ALL aggressive cleaning solutions and organic solvents whenever possible, including window cleaning spray, benzene, aggressive shampoos etc.

CAUTION: When flying in regions with a lot of bugs in the air the leading edges of the airframe (propeller, wings, tail) need to be protected before flight with antistatic furniture spray cleaner such as Pronto (transparent, manufacturer: Johnson Wax), or something equivalent. When using such spray, do not apply it directly onto the wing but onto a soft cloth instead (old T-shirts are best).

CAUTION: After having finished with flight activity for the day, clean the leading edges of the airframe as soon as possible with a lot of water and a drying towel (chamois, artificial leather skin). This will be very easy to do if the leading edge was sprayed with an anti-static spray cleaner before flight.

After-flight wash down

Bugs, which represent the most of the dirt to be found on the airframe, are to be removed with clean water and a soft cloth (this can also be done using a drying towel, chamois or artificial leather skin). Begin by soaking all the leading edges of the airframe first. Then wipe the aircraft's entire surface until it is completely dry. Clean the propeller and remove any grease spots separately using a mild car shampoo with a wax.

CAUTION: Do not, under any circumstances attempt to use aggressive cleaning solutions, as you will severely damage the lacquer, which is the only protective layer before the structural laminate.

When using the aircraft in difficult atmospheric conditions (intense sunshine, dusty winds, coastline, acid rains etc.) make sure to clean the outer surface more thoroughly.

CAUTION! Do not, under any circumstances attempt to remove such bug-spots with abrasive sponges and/or rough polishing pastes.

Periodical cleaning of all outer surfaces with car shampoo

It is recommended the aircraft be cleaned from top to bottom using a soft sponge. Be careful not to use a sponge that is contaminated with any fine particles, such as those found in mud and sand, as this could abrade/damage the surface. While cleaning, soak the surface and the sponge many, many times. Use a separate sponge to clean the bottom of the fuselage, as is it usually greasier than the rest of the airframe. When pouring water over the airframe, be careful not to direct it over the battery bay hatches, wing-fuselage joining chapter, parachute rescue system straps and cover, pitot tube, tail static probe and/or cowlings.

Always rinse the shampooed surfaces again before they dry, then just wipe the whole aircraft dry using a drying towel, chamois or artificial leather skin. Also, clean the control surface gap seals on the wing and empennage. Lift the seals gently and insert ONE layer of cloth underneath, then move along the whole span of the seal.

Cleaning the Lexan transparent surfaces

All the of the ALPHA Electro's window surfaces are made of Lexan. Cleaning Lexan is not the same as cleaning Plexiglas. It is really important to only use clean water (no cleaning solutions are necessary) when cleaning and a really clean drying towel.

CAUTION: Do not use the towel that was used to dry the airframe's surfaces to dry the window surfaces. Use another unused towel for the window surfaces.

Should the window surfaces be dusty, remove the dust first by pouring water (not spraying!) and gliding your hand over the surface. Glide the drying towel over the surface, squeeze it out and soak it before touching the glass again. If there are bugs on the windshield, soak them with plenty of water first, so less wiping is necessary. After drying the window surface, apply some anti-static furniture spray cleaner such as Pronto (transparent, manufacturer: Johnson Wax), or something similar and wipe the surface clean with a separate soft cotton cloth.

PIPISTREL

This page is intentionally left blank.

20

CHAPTER 20 – STANDARD PRACTICES – AIRFRAME

TABLE OF CONTENTS

SECTION	SUBJECT	PAGE NUMBER
20-00	GENERAL	20-03
20-10	SEALANTS AND LUBRICANTS Description	20-04
20-20	THREAD-LOCKING FLUIDS Description	20-05
20-30	FASTENER INFORMATION AND TORQUE VALUES Description	20-06
20-40	FASTENER/HARDWARE GENERAL REQUIREMENTS Description Maintenance practices	20-07
20-50	ADHESIVES Description	20-09

20-00 GENERAL

This chapter contains information about the standard practices that shall be followed when carrying out any maintenance procedures on the ALPHA Electro. It covers topics such as fastening hardware, torque values, approved thread locking fluids, sealants and adhesives.

20-10
SEALANTS AND LUBRICANTS

20-10 SEALANTS AND LUBRICANTS

1. Description

Table 20-001 outlines the sealants and lubricants that are approved for use on the ALPHA Electro.

Approved Sealants and Lubricants			
Item	Supplier	Specification	Pipistrel P/N
SKF general purpose grease	SKF group	LGMT 2/0.2	5092004
Würth white assembly paste	Adolf Würth GmbH & Co. KG	0893 1041	5092021
Super Impact grease	Xintex	502001	5092008
Krown Rust Inhibitor	Krown rust control systems	KL 73	5092020
Tekasil neutral profi white silicone	TKK Srpenica d.d.	-	5093024
Termosil 300°C neutral black silicone	TKK Srpenica d.d.	-	5093017
Termosil N6	TKK Srpenica d.d.	-	5093018
Loctite 577 thread sealant	Loctite Corp.	-	5091033

Table 20-001
Approved sealants and lubricants

NOTE: Please refer to the latest revision of the ALPHA Electro's IPC for additional information as to where the sealants/lubricants listed in Table 20-001 are used.

CAUTION: When using the sealants and lubricants listed in Table 20-001 always refer to the supplier's instructions for information about how to store them properly, how to use them properly and any safety precautions.

WARNING: Don't use any sealants or lubricants that have expired.

20-20 THREAD-LOCKING FLUIDS

1. Description

Table 20-002 outlines the thread-locking fluids that are approved for use on the ALPHA Electro.

Approved Thread-Locking Fluids			
Item	Supplier	Specification	Pipistrel P/N
Loctite 243	Loctite Corp.	-	5091023
Loctite 262	Loctite Corp.	-	5091024
Loctite 270	Loctite Corp.	-	5091025

Table 20-002
Approved thread-locking fluids

NOTE: Please refer to the latest revision of the ALPHA Electro's IPC for additional information as to where the thread-locking fluids listed in Table 20-002 are used.

CAUTION: When using the thread-locking fluids listed in Table 20-002 always refer to the supplier's instructions for information about how to store them properly, how to use them properly and any safety precautions.

WARNING: Don't use any thread-locking fluids that have expired.

WARNING: All of the ALPHA Electro's bolted joints requiring thread-locking fluids are labeled in the latest revision of its IPC. Failure to apply thread-locking fluids to the aforementioned bolted joints can cause them to loosen and possibly a safety hazard.

20-30
FASTENER INFORMATION AND
TORQUE VALUES

20-30 FASTENER INFORMATION AND TORQUE VALUES

1. Description

Information about the fastening material used on the ALPHA Electro can be found in the latest revision of the ALPHA Electro's IPC. The large majority of bolts used adhere to the DIN ("Deutsche Industrie Norm) standard. Any bolted joints that require special torqueing are labelled in the ALPHA Electro IPC. All other bolted joints that are otherwise not labeled with a specific torque, must be torqued to the values found in Table 20-003.

Fastener	Torque (Nm) based on bolt grade		
	8.8	10.9	12.9
M4	2.8	4.1	4.8
M5	5.5	8.1	9.5
M6	9.5	14.0	16.5
M8	23.0	34.0	40.0
M10	46.0	68.0	79.0
M12	79.0	117.0	135.0
M14	125.0	185.0	215.0

Table 20-003
Standard torque values for the ALPHA Electro

WARNING: Bolts on the ALPHA Electro are only permitted to be replaced by equal or better grade bolts.

CAUTION: When fastening bolted joints always torque the nuts whenever possible.

20-40 FASTENER/HARDWARE GENERAL REQUIREMENTS

1. Description

This chapter outlines the standard practices that apply to fastening material and hardware found on the ALPHA Electro. It covers the maintenance practices that apply to torque marking, proper use of locknuts and fittings with tapered thread.

2. Maintenance Practices

20-40: 2.1. Torque marking

Torque marking refers to act of marking a bolt joint after it's been torqued (see Figure 20-001). This allows for any loosening that may occur to be detected visually.

NOTE: All bolted joints on the ALPHA Electro must be torque marked after being torqued to ensure easy detection of any loosening.

CAUTION: The fastening material of any bolted joint that has loosened must be removed and replaced.



Figure 20-001
Example of torque marked bolted joints

20-40: 2.2. Locknuts

Locknuts are used throughout the ALPHA Electro because they resist loosening. Their plastic lining creates additional friction between it and the bolt.

CAUTION: Reusing locknuts is not permitted on the ALPHA Electro.

20-40

FASTENER /HARDWARE GENERAL REQUIREMENTS

20-40: 2.3. Fitting with tapered thread

Some of the components found on the ALPHA Electro have tapered NPT thread and thus require special attention when removing/installing them. All of the aforementioned components can be found in the latest revision of the ALPHA Electro IPC. The following points must be adhered to when working with tapered thread on the ALPHA Electro:

- An approved thread sealant (Loctite 577) must be applied to the external thread before fastening. This will ensure a leak-free seal.
- The component must be tightened by hand first and then tightened an additional two (2) turns with a wrench, so that the thread deforms and creates the seal.

CAUTION: Any components or fastening material with tapered thread, once removed, are not permitted to be reused and must be replaced with new ones.

20-50 ADHESIVES

1. Description

Table 20-004 outlines the adhesives that are approved for use on the ALPHA Electro.

Approved Sealants and Lubricants			
Item	Supplier	Specification	Pipistrel P/N
Tesa professional spray glue	Tesa SE	60022	5091063
Pattex universal classic contact adhesive	Henkel	-	5091011
Würth window adhesive classic plus	Adolf Würth GmbH & Co. KG	0890023701	5091018
Scotchmount primer	3M Deutschland GmbH	4297	5095009

Table 20-004
Approve adhesives

CAUTION: When using the adhesives listed in Table 20-004 always refer to the supplier's instructions for information about how to store them properly, how to use them properly and any safety precautions.

WARNING: Don't use any adhesives that have expired.

PIPISTREL

This page is intentionally left blank.

21

CHAPTER 21 – ENVIRONMENTAL SYSTEMS

TABLE OF CONTENTS

SECTION	SUBJECT	PAGE NUMBER
21-00	GENERAL	21-03
21-10	VENTILATION SYSTEMS Description Maintenance Practices	21-04

21-00 GENERAL

The chapter covers all of the systems that control/regulate air flow and temperature in the ALPHA Electro.

21-10
VENTILATION SYSTEMS

21-10 VENTILATION SYSTEMS

1. Description

The ALPHA Electro's primary ventilation system consists of circular adjustable vents that direct fresh ram air into the cockpit (See Figure 21-001).

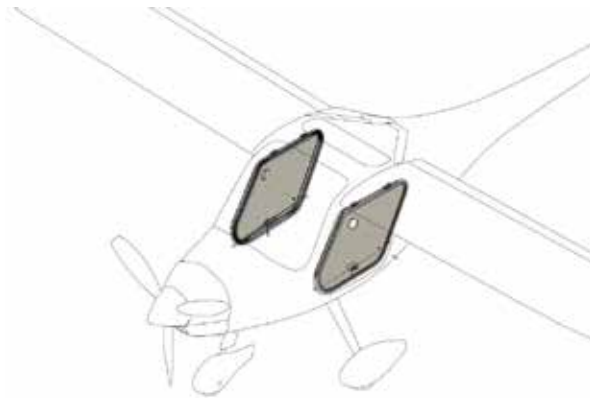

Figure 21-001
Primary ventilations system

2. Maintenance practices

21-10: 2.1. Primary ventilation system

21-10: 2.1.1. Inspection/check

Reference:

Step	Action	Required parts, materials and tools	Reference
1	Inspect the port door's adjustable circular vent for free, unhindered movement. Check for signs of damage and/or wear.		

24

CHAPTER 24 – ELECTRICAL POWER

TABLE OF CONTENTS

SECTION	SUBJECT	PAGE NUMBER
24-00	GENERAL	24-03
24-30	DC GENERATION	24-04
	Description Maintenance Practices	
24-60	DC ELECTRICAL LOAD DISTRIBUTION	24-07
	Description Maintenance Practices	

24-00 GENERAL

The ALPHA Electro is equipped with two metal battery boxes, which contain the battery cells, the BMS and communication modules, as well as the power and signal connectors. One of the boxes is positioned firewall forward, while the other is aft of the cabin bulkhead. Each of the battery boxes has an independent BMS, which monitors and balances the system's voltage. All the units communicate with the EPSI570 and log data from each individual battery cell. The electric motor is a 60 kW peak power unit capable of energy recuperation during descent.

24-30
DC GENERATION

24-30 DC GENERATION

1. Description

The ALPHA Electro is equipped with two 10.5 kWh battery boxes: one aft of the cabin bulkhead and the other aft of the firewall. Each battery box incorporates lithium-ion battery cells, BMS relays, power enable relays, communication modules and power/signal connectors. The battery system is ventilated to prevent overheating and thermally protected. The batteries are charged via an easily-accessible fast charge port located on the starboard side of the motor compartment.



Figure 24-001
Fore and aft battery boxes

2. Maintenance Practices

24-30: 2.1. Battery box

24-30: 2.1.1. Removal

CAUTION: Removing the fore battery box before the aft causes the aircraft CG to shift and the tail to drop. To prevent this from happening support the tail with a trestle.

Step	Action	Required parts, materials and tools	Reference
1	Open fore battery bay door.		
2	Ensure battery box is disconnected.		24-30: 2.1.3.
3	Support tail cone with trestle.		
4	Release latches securing battery box in battery bay.		
5	Slide battery box out of bay and place on flat, clean surface.		
6	Repeat procedure with aft battery box.		



Figure 24-002
Installed fore battery box

24-30: 2.1.2. Installation

CAUTION: Installing the aft battery box before the fore causes the aircraft CG to shift and the tail to drop. To prevent this from happening support the tail with a trestle.

Step	Action	Required parts, materials and tools	Reference
1	Open fore battery bay door.		
2	Slide battery box into battery bay.		
3	Lock latches securing battery box in battery bay.		
4	Locate data cable and power cable connectors.		
5	Connect power cable by plugging connector in and rotating lock handle upwards.		
6	Connect data cable by plugging connector in and tightening screws.		
7	Repeat procedure with aft battery box.		

24-30: 2.1.3. Disconnection

Step	Action	Required parts, materials and tools	Reference
1	Ensure aircraft main switches (MASTER, AVIONICS, BAT EN, PWR EN) are OFF.		
2	Open fore battery bay door.		
3	Locate data cable connector and power connector.		
4	Unscrew data cable screws and unplug connector.		
5	Disconnect power cable by lifting connector lock handle upwards and unplugging connector.		
6	Repeat procedure with aft battery box.		

24-60
DC ELECTRICAL LOAD
DISTRIBUTION

24-60 DC ELECTRICAL LOAD DISTRIBUTION

1. Description

The battery boxes are connected to a firewall-mounted junction box (see Figure 25-001) that incorporates the aircraft's main relays and a DC converter. The latter converts an input voltage of 300-400VDC into 12VDC and provides power for components such as the main computer, water pump, avionics, throttle lever, etc. There is also a firewall-mounted power controller that converts 400V input voltage into 3-phase 400V AC output voltage for the electric motor

The upper cowling has a hatch that provides easy access to the FCP fastened to the motor mount. The FCP has a cable-secured cap and a drain tube for water that may build up if the hatch is accidentally left open.

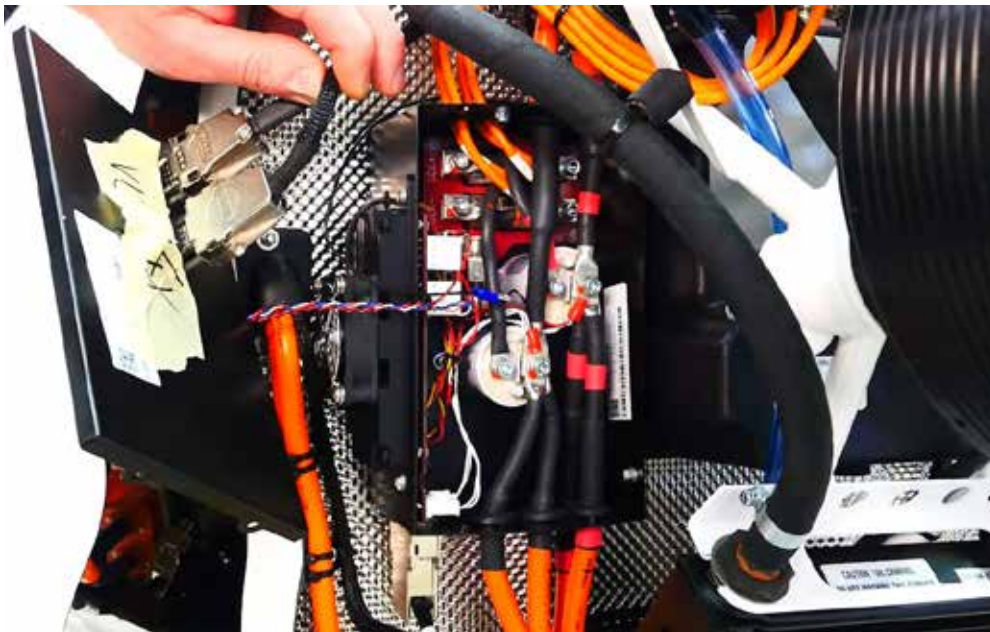

Figure 24-001
Junction box

2. Maintenance Practices

WARNING: Before performing any maintenance on electrical installations make sure the aircraft's main switches (MASTER, AVIONICS, BAT EN, PWR EN) are OFF and the batteries boxes are disconnected!

24-60: 2.1. Junction box

24-60: 2.1.1. Removal

Step	Action	Required parts, materials and tools	Reference
1	Support tail cone with trestle.		
2	Remove fore and aft battery boxes.		24-30:2.1.1.
3	Remove screw securing grounding wire to top of junction box.		
4	Disconnect three connectors from junction box.		
5	Unscrew the four cover screws and remove cover.		
6	Disconnect both connectors from junction box cover.		
7	Remove screws securing power cable lugs to terminals.		
8	Cut four FCP wires where they enter the junction box.		

NOTE: Cutting the FCP wires on newer ALPHA Electro aircraft is not necessary. Just release lugs and remove from junction box.

9	Remove power cables and FCP wires from junction box.		
10	Remove screws securing junction box to firewall from inside of fore battery bay.		
11	Remove junction box.		

24-60: 2.1.2. Installation

Step	Action	Required parts, materials and tools	Reference
1	Locate replacement junction box.		
2	Remove cowlings.		71-10: 2.1.1.
3	Remove aft and fore battery box.		24-30: 2.1.1.
4	Fasten junction box to firewall from inside of fore battery bay.		
5	Remove junction box cover screws and remove cover.		
6	Plug harness between power controller and junction box into bottom of junction box and tighten screws.		91-00

continued on the next page

24-60 DC ELECTRICAL LOAD DISTRIBUTION

Step	Action	Required parts, materials and tools	Reference
7	Run both fore battery box power cables and both aft battery box power cables into junction box (positive cables through bottom port holes and negative cables through bottom starboard holes).		
8	Run both power cables from power controller through holes in top junction box holes.		
9	Run FCP wires into junction box and fit them with lugs. NOTE: On new release of Alpha Electro this step is not necessary as wires are already equipped with lugs.		
10	Fasten FCP positive cable lugs to port terminals and FCP negative cable lugs to starboard terminals.		91-00
11	Fasten negative power cables to starboard capacitor and positive power cables to port capacitor.		91-00
12	Connect both white connectors to junction box cover.		

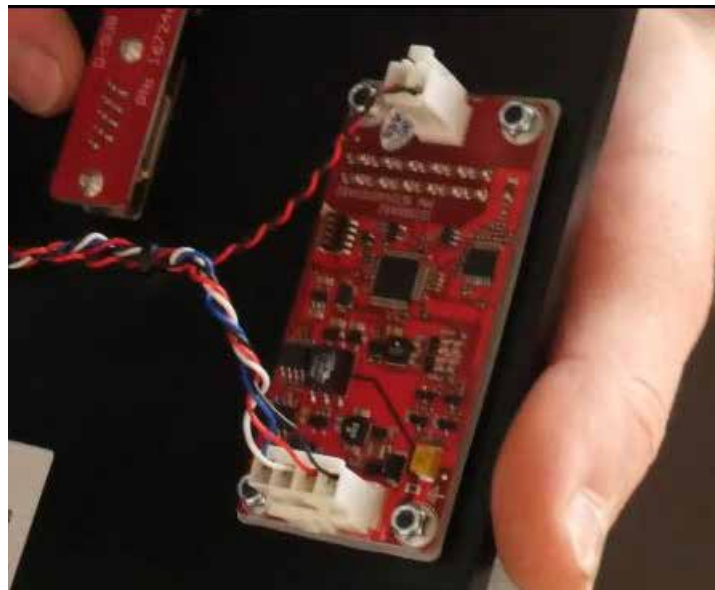

Figure 24-002
Connectors on junction box cover

13	Fasten junction box cover to junction box.		
14	Connect date cables to junction box cover.		
15	Fasten grounding wire to top of junction box.		Figure 24-003
16	Install aft and fore battery box.		24-30: 2.1.2.
17	Install cowlings.		71-10: 2.1.2.

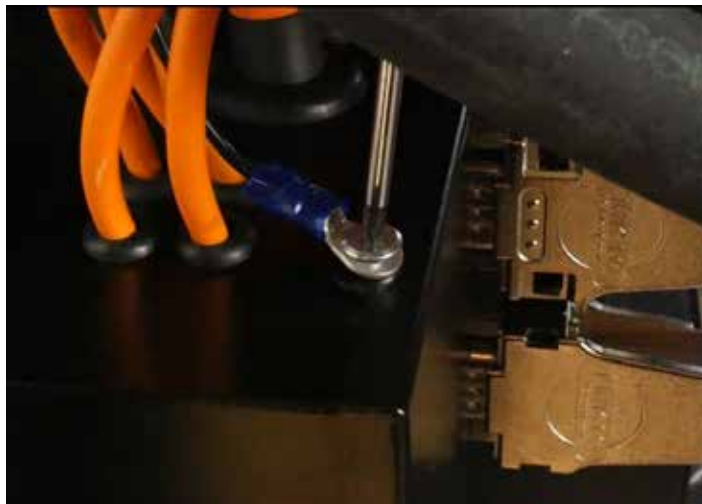

Figure 24-003
Fastening grounding wire to top of junction box

24-60: 2.1.3. Inspection/check

Step	Action	Required parts, materials and tools	Reference
1	Remove cowlings.		71-10: 2.1.1.
2	Remove aft and fore battery box.		24-30: 2.1.1.
3	Remove screws securing junction box cover to junction box.		
4	Remove junction box cover.		
5	Ensure power cables are securely fastened to charging relay terminals. Tighten if necessary.		
6	Reinstall junction box cover.		
7	Install aft and fore battery box.		24-30: 2.1.2.
8	Install cowlings.		71-10: 2.1.2.

24-60
DC ELECTRICAL LOAD
DISTRIBUTION

24-60: 2.2. FCP

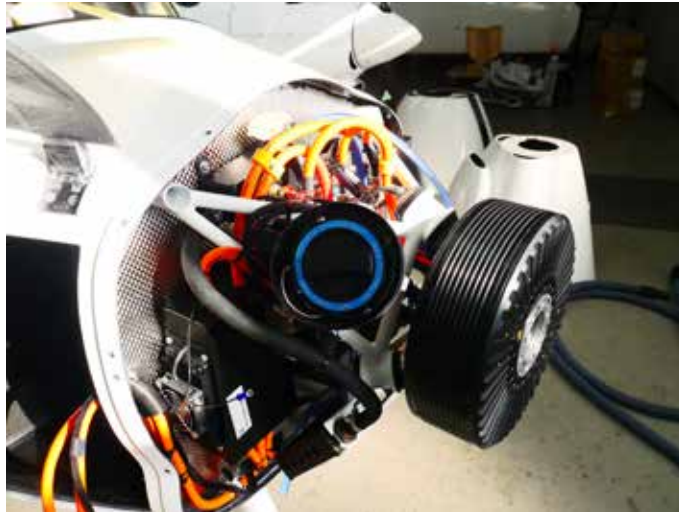

Figure 24-003
Fast charge port (FCP)

24:60: 2.2.1. Removal

Step	Action	Required parts, materials and tools	Reference
1	Remove cowlings.		71-10: 2.1.1.
2	Remove aft and fore battery box.		24-30: 2.1.1.
3	Remove screws securing junction box cover to junction box.		
4	Remove junction box cover.		
5	Cut any plastic zip ties securing FCP wires/cables to motor mount.		
6	Disconnect or cut the wires running into junction box from FCP.		91-00
7	Cut harness between FCP and instrument panel.		
8	Remove four screws securing FCP to motor mount.		
9	Remove the FCP.		
10	Install aft and fore battery box.		24-30: 2.1.2.
11	Install cowlings.		71-10: 2.1.2.

24-60: 2.2.2. Installation

Step	Action	Required parts, materials and tools	Reference
1	Remove cowlings.		71-10: 2.1.1.
2	Remove aft and fore battery box.		24-30: 2.1.1.
3	Cut cable securing FCP cap to FCP and remove cap.		Figure 24-004
4	Remove screw securing side tabs and drain tube to FCP housing.		
5	Slide harness through mounting flange and position new FCP.		
6	Apply Loctite 243 to nuts and fasten FCP to mounting flange.		
7	Reinstall side tabs.		
8	Apply grease to drain tube tab screws and reinstall tab.		12-10
9	Reconnect/crimp FCP cap to cable.		
10	Reinstall junction box cover.		
11	Install aft and fore battery box.		24-30: 2.1.2.
12	Install cowlings.		71-10: 2.1.2.



Figure 24-004
Cutting FCP cap cable

PIPISTREL

This page is intentionally left blank.

25

CHAPTER 25 – EQUIPMENT AND FURNISHING

TABLE OF CONTENTS

SECTION	SUBJECT	PAGE NUMBER
25-00	GENERAL	25-03
25-10	FLIGHT COMPARTMENT	25-04
	Description Maintenance Practices	
25-60	EMERGENCY	25-07
	Description Maintenance Practices	

25-00 GENERAL

This chapter describes all of the equipment and furnishings found in the cabin of the ALPHA Electro. It covers everything from the seats and three-point seat safety harnesses to the upholstery and control stick boots.

25-10
FLIGHT COMPARTMENT

25-10 FLIGHT COMPARTMENT

1. Description

This chapter describes all of the equipment and furnishings found in the cabin and outlines the maintenance practices that apply to them.

Crew seats

The crew seats are comprised of a bottom cushion, hard padded back rest and a head rest. The backrest and head rest are attached to the aft cabin bulkhead, while the bottom cushion is attached to the seat shell. All of the seats' components are secured in place by means of Velcro patches. The seats' position cannot be adjusted, nor can they be reclined, however the backrest features a manual pneumatic pump to adjust the size of the lumbar bladder and consequently the amount of back support.

Safety harnesses

The harness is a 4-point restraint system with quick release buckle. The lap straps are attached to the composite seat shell with M8 bolts in an area that is locally reinforced. The shoulder straps are attached to the top of the aft battery bay bulkhead with M8 bolts. The attachment point is also locally reinforced.

Control stick boots

Each control stick is equipped with a leather boot that protects the stick and prevents any dirt/debris from entering the area beneath the cabin floor.

2. Maintenance practices

25-10: 2.1. Crew seats

25-10: 2.1.1. Removal

Step	Action	Required parts, materials and tools	Reference
1	Tear head rest away from Velcro patches and remove it.		
2	Tear backrest away from Velcro patches, slide shoulder straps around it and remove it.		
3	Tear bottom cushion away from Velcro patches and remove it.		
4	Carry out visual inspection.		05-20

25-10: 2.1.2. Installation

Step	Action	Required parts, materials and tools	Reference
1	Position bottom cushion in seat shell and press it up against the Velcro patches on the seat shell.		
2	Position the backrest behind the shoulder straps and press it up against the Velcro patches on the aft cabin bulkhead.		
3	Position the head rest so that it's bottom flap rests behind the backrest and then press it up against Velcro patches on the aft cabin bulkhead.		

25-10: 2.2. Safety harnesses

25-10: 2.2.1. Removal

Step	Action	Required parts, materials and tools	Reference
1	Remove crew seats.	T-handle socket screwdriver set	25-10
2	Remove fastening material securing the harnesses to their attachment points.		
3	Remove safety harnesses.		
4	Carry out visual inspection.		05-20

25-10: 2.2.2. Installation

Step	Action	Required parts, materials and tools	Reference
1	Apply Loctite 243 to the fastening material thread.	- T-handle socket screwdriver set, - Loctite 243	
2	Fasten the safety harnesses to their attachment points.		
3	Install crew seats.		25-10
4	Carry out operational inspection of seats.		05-20

25-10: 2.3. Control stick boot

25-10: 2.3.1. Removal

Step	Action	Required parts, materials and tools	Reference
1	Remove the self-tapping screws securing the base of the boot in place.	Phillips screwdriver	
2	Release the strap at the top of the boot.		
3	Remove the boot by sliding it off the control stick.		
4	Carry out visual inspection.		05-20

25-10
FLIGHT COMPARTMENT

25-10: 2.3.2. Installation

Step	Action	Required parts, materials and tools	Reference
1	Slide the boot over the control stick and position it on the cabin floor	Phillips screwdriver	
2	Fasten it to the cabin floor using the self-tapping screws		
3	Fasten the strap at the top of the boot		
4	Carry out operational inspection of the control stick.		05-20

25-60 EMERGENCY

1. Description

Emergency locator transmitter (ELT)

ALPHA Electro aircrafts are equipped with two different ELT models; Kannad 406 AF Compact ELT and Artex ELT 345. In both cases, the ELT transmitter is installed immediately aft of the cabin bulkhead. The ELT is mounted slightly to the right of the airplane centerline. The transmitter is accessible by removing the seats, while the ELT antenna is located on the top of the cockpit.

Kannad 406 RCP / Artex 345 RCS

The Kannad 406 AF Compact ELT has a remote control panel (RCP) Kannad RC200, installed on the instrument panel for easy access and checking of system's proper functionality.

The Artex 345 has a remote control switch, installed on the instrument panel for easy access and checking of system's proper functionality.

WARNING: ELT and RCP / RCS batteries must be inspected in accordance with the requirements of the replacement schedule in chapter 5. The ELT and RCP / RCS batteries must be replaced upon reaching the date stamped on the batteries or whenever the batteries have been in use for one cumulative hour.

NOTE: Electrical equipment and electrically powered instruments are individually protected by means of circuit breakers, except the ELT which is separate from electrical system of the aircraft.

For additional information of the ELT, refer to the Kannad 406 AF Compact ELT Installation and Operation Manual or to Artex ELT 345 ELT Installation and Operation Manual.

25-60
EMERGENCY

2. Maintenance practices

25-60: 2.1. Kannad 406 AF Compact ELT

25-60: 2.1.1. Removal

Step	Action	Required parts, materials and tools	Reference
1	Remove crew seats.		25-10
2	Locate ELT behind passenger seat.		
3	Set the 3-position switch of the front panel to OFF.		
4	Disconnect the antenna cable from the BNC connector of the ELT.		
5	Disconnect the DIN 12 Connector of the RCP from the DIN 12 socket of the ELT.		
6	Release strap.		
7	Remove ELT.		
8	Carry out visual inspection.		05-20

25-60: 2.1.2. Installation

Step	Action	Required parts, materials and tools	Reference
1	Position ELT in mounting brace with "Flight direction" arrow pointing towards the front of the aircraft.		
2	Secure strap tightly.		

NOTE: Once installed in the mounting brace, the installer must be sure that the transmitter is firmly attached in its bracket by trying to extract it manually, thereby verifying there is no play and that it remains attached when extraction from the bracket is attempted.

3	Connect the antenna cable to the BNC connector of the ELT.		
4	Connect the DIN 12 Connector of the RCP to the DIN 12 socket of the ELT.		
5	Set the 3-position switch of the front panel to ARM.		

NOTE: To avoid inadvertent activation or to save ELT's battery, set the switch to OFF when:

- aircraft is about to be shipped
- maintenance will be performed
- aircraft is about to be stored for a longer period

NOTE: Make sure, that switch is set back to ARM before next flight.

6	Install crew seats.		25-10
---	---------------------	--	-------

25-60: 2.2. Artex ELT 345

25-60: 2.2.1. Removal

Step	Action	Required parts, materials and tools	Reference
1	Remove crew seats.		25-10
2	Locate ELT behind passenger seat.		
3	Disconnect antenna coax cable from the ELT.		
4	Disconnect RCS harness D-sub plug.		
NOTE: Check the coax cable center conductor pin which is prone to retracting into the connector housing.			
5	Release the metal harness.		
6	Slide the ELT up and out, and away from the mounting tray.		
7	Carry out visual inspection.		05-20

25-60: 2.2.2. Installation

Step	Action	Required parts, materials and tools	Reference
1	Insert the ELT into the mounting tray at an angle, engaging the locking ears at the tail end first. Press the ELT down until it is fully seated in the mounting tray.		
2	Secure the metal harness.		
3	Connect the RCS harness to the ELT, taking care to insert the D-sub receptacle straight in. Secure the D-sub receptacle with the thumb-screws.		
NOTE: Care must be taken in the cable connection process to avoid shorting any pins to ground or each other. Under some circumstances, the shorting or grounding of the pins signal the ELT as if the remote switch was activated. This may result in ELT transmissions or setting the ELT into a monitoring condition. This may result in the ELT exhibiting battery runtime in excess of regulations. To avert this condition, after the harness connection is complete the installer shall activate the self-test on the installed unit. This action will need to be performed whenever the harness is disconnected and then re-connected.			
4	Connect the antenna coax cable to the ELT.		
5	Install crew seats.		25-10

PIPISTREL

This page is intentionally left blank.

27

CHAPTER 27 – FLIGHT CONTROLS

TABLE OF CONTENTS

SECTION	SUBJECT	PAGE NUMBER
27-00	GENERAL	27-03
	Description Maintenance Practices	
27-20	RUDDER	27-04
	Description Maintenance Practices	
27-30	ELEVATOR	27-14
	Description Maintenance Practices	
27-50	FLAPERONS	27-21
	Description Maintenance Practices	

27-00 GENERAL

1. Description

This chapter describes the ALPHA Electro's control system and the maintenance procedures that pertain to it.

The ALPHA Electro's control system consists of various push/pull rods, bellcranks, cables and pulleys. An elevator attached to the horizontal stabilizer gives longitudinal control, while a rudder, which is attached to the vertical stabilizer, provides yaw control. The wings have flaperons attached to their trailing edge which provide lateral control, as well as extra lift for landing and taking off.

The ALPHA Electro has a control stick for each pilot. The elevator can be trimmed using a trim knob found in the center console, just between the two seats.

Each pilot has a rudder pedal assembly that is attached to the cabin floor and allows for complete yaw control as well as nose wheel steering. The rudder pedal assembly's position is adjustable.

2. Maintenance Practices

27-00: 2.1. Push/pull rods

27-00: 2.1.1. Adjusting length

Reference:

Step	Action	Required parts, materials and tools	Reference
1	Loosen jam nut.	- metric ratchet/socket set, - metric combination wrench set	05-20
2	Remove fastening material securing the rod end to the stud/brace.		
3	Slide rod end off stud/brace.		
4	Rotate rod end bearing clockwise to shorten the push/pull rod or counterclockwise to lengthen it.		
5	Slide rod end back onto stud/brace.		
6	Fasten rod to stud/brace. Torque and apply Loctite if necessary (see pull/push rod assembly in IPC).		
7	Carry out operational inspection.		

27-20 RUDDER

1. Description

Rudder pedals are available for each pilot and are adjustable in flight in the fore-aft direction. Metal cables in Teflon-coated protective sleeves run from the individual pedal under the seat pan and aft battery bay, to the rudder bell crank. Rudder neutralization is achieved by means of two retaining springs. The nose wheel is part of the yaw control system and moves whenever the pedal is pressed.

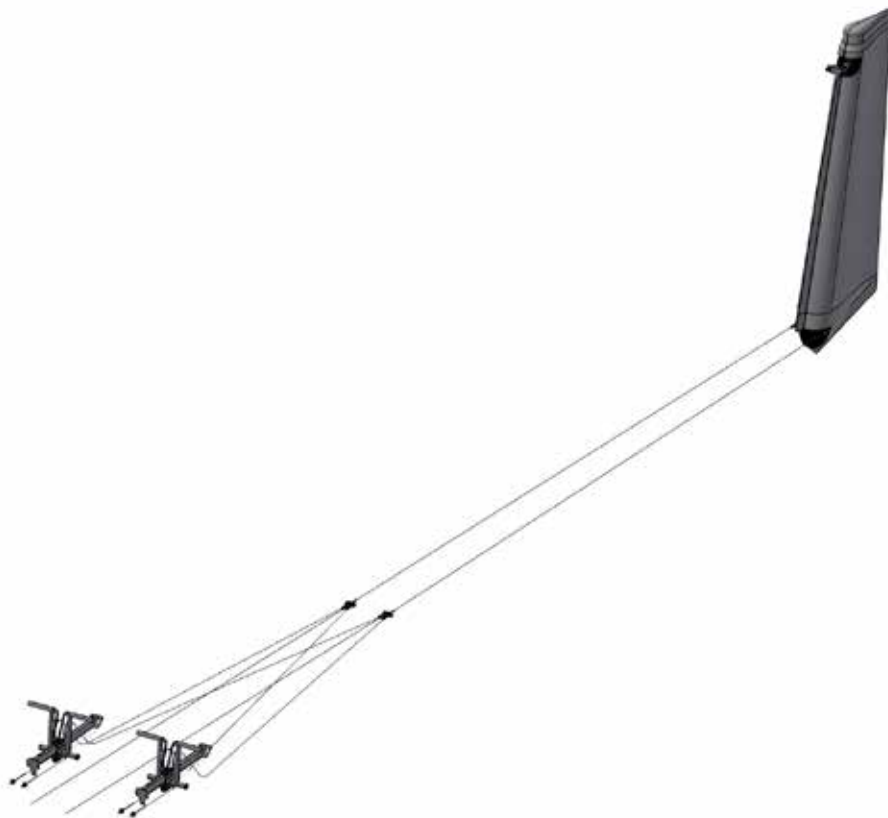

Figure 27-001
Rudder control system

2. Maintenance Practices

27-20: 2.1. Rudder cables

27-20: 2.1.1. Inspection/check near the rudder

Reference:

Step	Action	Required parts, materials and tools	Reference
1	Remove rudder.	- metric ratchet/socket set	55-40
2	Carry out visual inspection of rudder cables in the vicinity of the rudder cable bellcrank.		05-20
NOTE: Pay special attention to the cables' individual strands, as if even one damaged strand requires complete cable replacement. Also inspect their thimbles and sleeves for any signs of damage or wear.			
3	Carry out operational inspection of the rudder cables in the vicinity of the rudder cable bellcrank.		05-20
4	Install the rudder.		55-40

27-20: 2.1.2. Inspection/check in the fuselage aft of the cabin

Reference:

Step	Action	Required parts, materials and tools	Reference
1	Remove aft battery box.	- metric ratchet/socket set	24-30: 2.1.1.
2	Remove aft battery bay.	- T-handle hex head screwdriver set	24-30
3	Carry out visual inspection of rudder cables behind the cabin and in the fuselage tail cone.		05-20
NOTE: Pay special attention to the cables' individual strands, as if even one damaged strand requires complete cable replacement.			
4	Carry out operational inspection of the rudder cables behind the cabin and in the fuselage tail cone.		05-20
5	Install aft battery bay.		24-30
6	Install aft battery box.		24-30: 2.1.2.

27-20: 2.1.3. Inspection/check in the cabin

Reference:

Step	Action	Required parts, materials and tools	Reference
1	Carry out visual inspection of rudder cables in the cabin near the rudder pedals.		05-20

NOTE: Pay special attention to the cables' individual strands, as if even one damaged strand requires complete cable replacement.

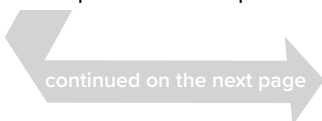

27-20
RUDDER

Step	Action	Required parts, materials and tools	Reference
2	Carry out operational inspection of the rudder cables in the cabin.		05-20
3	Detach the rudder pedal return springs to access to the bottom end of the S-shaped tube.		
NOTE: Pay special attention to the area where the cables enter and exit the pedals' S-shaped tube (see Figure 27-002).			
4	Reattach the rudder pedal return springs.		



Figure 27-002
Upper pedal-rudder cable joint

27-20: 2.2. Rudder pedals

27-20: 2.2.1. Inspection/check

Reference:

Step	Action	Required parts, materials and tools	Reference
1	Carry out visual inspection of rudder pedals.		05-20
2	Carry out operational inspection of rudder pedals.		05-20

27-20: 2.3. Rudder pedal return springs

27-20: 2.3.1. Inspection/check

Step	Action	Required parts, materials and tools	Reference
1	Carry out visual inspection of the springs. Pay special attention to the springs' end hooks and check for any signs of deformation.	Rudder deflection verification template (P/N 1190345)	05-20
2	Fit the aircraft with the rudder deflection verification template.		
3	Align the rudder with the template's center mark.		
4	Verify that the rudder pedals are parallel to each other.		

CAUTION: Damaged or deformed rudder pedal return springs can cause unexpected/odd yaw behavior. Replace them if necessary (see 27-20).

5	Remove the rudder deflection verification template.		
---	---	--	--

27-20: 2.3.2. Removal/installation

Step	Action	Required parts, materials and tools	Reference
1	Unhook the springs from the pedals.	- Vernier caliper - needle nose pliers - rudder deflection verification template (P/N 1190345)	27-20
2	Install new springs.		
3	Check that the rudder pedals are parallel to each other with the rudder centered.		
4	Carry out operational inspection of the rudder pedal return springs.		

27-20: 2.4. Rudder

27-20: 2.4.1. Inspect/check

Reference:

Step	Action	Required parts, materials and tools	Reference
1	Remove rudder.		55-40
2	Inspect the paint marker on the threaded stopper pins. If they have loosened/shifted, adjust the deflection angle.		20-40: 2.1. 27-20: 2.4.2.
3	Wipe clean and lubricate upper rudder bushing.		12-20

27-20
RUDDER

27-20: 2.4.2. Deflection angle adjustment

Reference:

Step	Action	Required parts, materials and tools	Reference
1	Position and fasten the rudder deflection template to the fuselage.	- rudder deflection verification template (P/N 1190345)	05-20
2	Verify that rudder's deflections angles are within tolerance using markings on template.		
3	If necessary, adjust deflection angles by screwing/unscrewing threaded stopper pins on lower rudder hinge.		

CAUTION: Rudder deflection angles that don't adhere to those in ALPHA Electro's weight and balance report (WBR 167-08-10-001) can result in unexpected/odd yaw behavior.

27-20: 2.4.3. Radial free play check

Reference: Figure 27-004

Step	Action	Required parts, materials and tools	Reference
1	Remove the horizontal stabilizer.	- Vernier caliper	53-10
2	Place Vernier caliper between rudder and the elevator retainer and, while moving the rudder back and forth in the radial direction, measure the free play.		
3	Install the horizontal stabilizer.		53-10

CAUTION: The maximum permissible amount of radial rudder free play is 0.5 mm.



Figure 27-004
Rudder radial free play check

27-20: 2.4.4. Axial free play check

Reference: Figure 27-005

Step	Action	Required parts, materials and tools	Reference
1	Remove the horizontal stabilizer.	- Vernier caliper	55-10
2	Place Vernier caliper as shown in Figure 27-005 and, while moving the rudder back and forth in the axial direction, measure the free play.		

CAUTION: The maximum permissible amount of radial rudder free play is 0.1 mm.

3	Install the horizontal stabilizer.		55-10
---	------------------------------------	--	-------



Figure 27-005
Rudder axial free play check

27-20: 2.5. Upper rudder hinge

27-20: 2.5.1. Inspection/check

Reference:

Step	Action	Required parts, materials and tools	Reference
1	Remove rudder.	- metric ratchet/socket set - torque wrench - paper towel	55-40
2	Carry out visual inspection of upper rudder hinge.		05-20
3	Inspect paint marker.		20-40: 2.1.
4	Clean hinge pin with paper towel and lubricate it.		12-20
5	Install rudder.		55-40

27-20
RUDDER

27-20: 2.6. Lower rudder hinge

27-20: 2.6.1. Inspection/check

Reference:

Step	Action	Required parts, materials and tools	Reference
1	Remove rudder.	- metric ratchet/socket set - torque wrench - paper towel	55-40
2	Carry out visual inspection of lower rudder hinge.		05-20
3	Inspect paint marker.		20-40: 2.1.
4	Clean hinge pin with paper towel and lubricate it.		12-20
5	Install rudder.		55-40

27-20: 2.7. Rudder cable bellcrank

27-20: 2.7.1. Inspection/check

Reference:

Step	Action	Required parts, materials and tools	Reference
1	Remove rudder.		55-40
2	Carry out visual inspection of rudder cable bellcrank.		05-20
3	Clean it with paper towel and lubricate it.		12-20
4	Inspect paint marker.		20-40: 2.1.
5	Carry out operational inspection of the rudder cable bellcrank.		05-20
6	Install rudder.		55-40

27-30 ELEVATOR

1. Description

The ALPHA Electro's elevator is fastened to the horizontal stabilizer and is operated using the pilot control sticks (see Figure 27-006). The sticks are mounted on a common lateral drive assembly, which actuates the horizontal elevator pushrod that runs along the entire length of the fuselage. A bellcrank is located on the bottom side of the vertical stabilizer and can be inspected through a provision in the vertical stabilizer end-rib. The hook-up to the elevator is via a composite U-shaped retainer which conforms to the shape of the elevator. Upon removal of the horizontal stabilizer/elevator, the U-member remains attached to the fuselage. The pitch control system does not include any cables. Control stops are integrated into the lateral drive assembly for elevator deflection control.



Figure 27-006
Elevator control system

27-30
ELEVATOR

A spring-based elevator trim is activated by a linear servo motor assembly located behind the aft battery bay (see Figure 27-007). The motion of the linear servo is controlled through a cockpit switch and an integral position sensor. Trim position is indicated with discrete steps on a dedicated LED display adjacent to the trim switch.



Figure 27-007
Elevator trim system and cockpit switch/display

2. Maintenance Practices

27-30: 2.1. Elevator

27-30: 2.1.1. Inspection/check

Reference:

Step	Action	Required parts, materials and tools	Reference
1	Remove the port control stick boot.		25-10
2	Inspect the paint marker on the threaded stopper pins at port end of the control stick drive. If they have loosened/shifted, adjust the deflection angle.		27-30: 2.1.2.

27-30: 2.1.2. Deflection angle adjustment

(if required after performing inspection/check in 27-30: 2.1.1. Inspection/check)

Reference:

Step	Action	Required parts, materials and tools	Reference
1	Fit elevator deflection measurement tool on trailing edge of elevator.	- elevator deflection measurement kit (P/N 1190464)	Figure 27-016
2	Put elevator in neutral position by aligning it with horizontal stabilizer. Set inclinometer to 0°.		
3	Verify the elevator's deflection angles adhere to those found in the ALPHA Electro's Weight and Balance Report (WBR 167-08-10-001)		
4	Adjust the deflection angles by screwing/unscrewing the control sticks' longitudinal threaded stopper pins.		05-20

CAUTION: Elevator deflection angles that don't adhere to those in ALPHA Electro's weight and balance report (WBR 167-08-10-001) can result in unexpected/odd pitch behavior.



Figure 27-0016

Elevator deflection angle adjustment

27-30: 2.1.3. Axial free play check

Reference: Figure 27-008

Step	Action	Required parts, materials and tools	Reference
1	Lower the tail chapter to the ground.	- Vernier caliper	
2	Place Vernier caliper between elevator and horizontal stabilizer, while moving the rudder back and forth in the axial direction, measure the free play.		Figure 27-008

CAUTION: The maximum permissible amount of axial elevator free play is 0.5 mm

27-30
ELEVATOR



Figure 27-008
Elevator axial free play check

27-30: 2.1.4. Radial free play check

Reference: Figure 27-005

Step	Action	Required parts, materials and tools	Reference
1	Lower the tail chapter to the ground	- Vernier caliper	Figure 27-009
2	Place Vernier caliper between elevator and horizontal stabilizer, while moving the rudder back and forth in the radial direction, measure the free play.		
CAUTION:	The maximum permissible amount of radial rudder free play is 0.5 mm.		
3	Install the horizontal stabilizer.		55-10



Figure 27-009
Elevator radial free play check

2.2. Horizontal elevator pushrod

27-30: 2.2.1. Inspection/check

Reference:

Step	Action	Required parts, materials and tools	Reference
1	Remove the crew seats.		25-10
2	Remove the aft battery box.		24-30: 2.1.1.
3	Remove the aft battery bay.		
4	Carry out visual inspection of horizontal elevator pushrod. Inspect the push rod's surface where it travels through the bearings. Surface discoloration is acceptable, however, gouges and surface deformations are not.		05-20 Figure 27-010 Figure 27-011
5	Carry out operational inspection of horizontal elevator pushrod.		05-20

CAUTION: Surface damage and/or gouges in the horizontal elevator pushrod deeper than 0.15 mm are a safety hazard and require pushrod replacement.



Figure 27-010
Horizontal elevator pushrod surface discoloration



Figure 27-011
Horizontal elevator pushrod surface gouges

27-30
ELEVATOR

27-30: 2.2.2. Major inspection

Reference:

Step	Action	Required parts, materials and tools	Reference
1	Remove the control stick boots.	Phillips screwdriver	25-10
2	Remove the crew seats.		24-30
3	Remove aft batter box.		05-20
4	Remove aft battery bay.		24-30
5	Use borescope to carry out visual inspection of the horizontal elevator push rod under the cabin floor.		24-30: 2.1.2.
6	Install aft battery bay.		25-10
7	Install aft battery box.		
8	Install the crew seats.		
9	Install control stick book.		

27-30: 2.3. Elevator trim assembly

27-30: 2.3.1. Inspection/check

Reference:

Step	Action	Required parts, materials and tools	Reference
1	Remove the crew seats.	- Vernier caliper, - measuring tape	25-10
2	Remove aft battery box.		24-30
3	Remove aft battery bay.		
4	Carry out visual inspection of elevator trim assembly. Inspect its springs for any signs of damage. Check that the fastening material securing them to the assembly hasn't loosened. Make sure their end hooks aren't deformed. Replace if necessary.		05-20 Figure 27-012
5	Carry out operational inspection of elevator trim assembly, including the elevator trim knob.		05-20
6	Verify that the hose clamps, securing the elevator trim assembly's springs to the horizontal elevator push-rod, haven't shifted in position. With the elevator and control sticks fixed in the neutral position, they must adhere to the following dimensions: Fore hose clamp: 60 mm between hose clamp and bearing housing. Aft hose clamp: 3 mm between hose clamp and bearing housing.		
6	Install aft battery bay.		24-30
	Install aft battery box.	24-30: 2.1.2.	
7	Install the crew seats.	25-10	

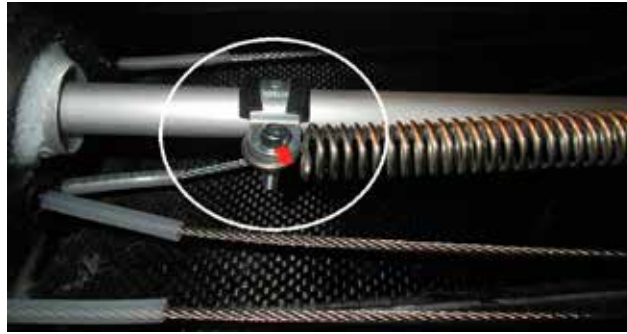

Figure 27-012
Elevator trim assembly spring fastening material

27-30: 2.4. Control sticks

27-30: 2.4.1. Inspection/check

Reference:

Step	Action	Required parts, materials and tools	Reference
1	Remove the control stick boots.	Phillips screwdriver	25-10
2	Carry out visual inspection of the control sticks.		05-20
3	Carry out operational inspection of the control sticks.		
4	Secure one control stick so that it can't move and move the other back and forth laterally. Measure the amount of free play.		

CAUTION: More than 8 mm of control stick free play is unacceptable and must be attended to immediately.

5	Carry out the same free play check for the other control stick.		
6	Install the control stick boots.		25-10

27-30: 2.4.2. Major inspection

Reference:

Step	Action	Required parts, materials and tools	Reference
1	Remove the control stick boots.	Phillips screwdriver	25-10
2	Use borescope to carry out visual inspection of the control sticks.		05-20
3	Install the control stick boots.		25-10

27-30
ELEVATOR

27-30: 2.5. Control stick drive

27-30: 2.5.1. Inspection/check

Reference:

Step	Action	Required parts, materials and tools	Reference
1	Remove the control stick boots.	Phillips screwdriver	25-10
2	Carry out visual inspection of the control stick drive.		05-20
3	Carry out operational inspection of the control stick drive.		
4	Lubricate drive's end bearings and all adjacent rod end bearings.		12-20
5	Install the control stick boots.		25-10

27-30: 2.5.2. Major inspection

Reference:

Step	Action	Required parts, materials and tools	Reference
1	Remove the control stick boots.	Phillips screwdriver	25-10
2	Use borescope to carry out visual inspection of the control stick drive assembly.		05-20
3	Install the control stick boots.		25-10

27-30: 2.6. Vertical elevator push rod

27-30: 2.6.1. Inspection/check

Reference:

Step	Action	Required parts, materials and tools	Reference
1	Remove the horizontal stabilizer.	Phillips screwdriver	55-10: 2.1.
2	Remove rudder.		55-40: 2.1.
3	Carry out visual inspection of the vertical elevator push rod.		
4	Carry out operational inspection of the vertical elevator push rod.		05-20
5	Lubricate push rod end bearings and aft horizontal elevator push rod end bearing.		12-20

27-30: 2.6.2. Major inspection

Reference:

Step	Action	Required parts, materials and tools	Reference
1	Remove the horizontal stabilizer.	Phillips screwdriver	55-10: 2.1.
2	Remove rudder.		55-40: 2.1.
3	Use borescope to carry out visual inspection of the vertical elevator push rod from the opening in the lower rudder hinge.		05-20

27-50 FLAPERONS

1. Description

Roll control of the ALPHA Electro is accomplished via symmetric deflection of the flaperons. The flaperon control system consists of various bellcranks, push/pull rods and torque tubes (see Figure 27-013). The pilots can change the flaperon deflection angle using a lever located between the seats. The lever's handle is spring-locked and has 3 marked positions corresponding to flap deflections of 0° , $+15^\circ$ and $+25^\circ$. The thumb-lock button prevents inadvertent lever movement. The aft end of the flap lever connects to the main flaperon bellcrank.



Figure 27-013
Flaperon control system

27-50
FLAPERONS

2. Maintenance Practices

27-50: 2.1. Flaperons

27-50: 2.1.1. Inspection/check

Reference:

Step	Action	Required parts, materials and tools	Reference
1	Remove the control stick boots.		25-10
2	Inspect the paint marker on both stopper bolts found on the top of the control stick drive. If they have loosened/shifted, adjust the flaperon deflection angle.		27-50: 2.1.2.

27-50: 2.1.2. Deflection angle adjustment

(if required after performing inspection/check 27-50: 2.1.1.)

Reference:

Step	Action	Required parts, materials and tools	Reference
1	Fit flaperon deflection measurement tool to trailing edge of verification template.	- flaperon deflection measurement kit (P/N 1190463)	Figure 27-0017
2	Put flaperon in neutral position by aligning it with wing. Set inclinometer to 0°.		
3	Verify that the deflection angles of both flaperons adhere to those found in the ALPHA Electro's Weight and Balance Report (WBR 167-08-10-001) in all of the different flaperon handle positions.		
4	Adjust the deflection angles by screwing/unscrewing the control sticks' lateral threaded stopper pins.		

CAUTION: Flaperon deflection angles that don't adhere to those in ALPHA Electro's weight and balance report (WBR 167-08-10-001) can result in unexpected/odd roll behavior.



Figure 27-0017
Flaperon deflection angle adjustment

27-50: 2.1.3. Axial free play check

Reference: Figure 27-014

Step	Action	Required parts, materials and tools	Reference
1	Remove the wings.	Vernier caliper	57-10
2	Place Vernier caliper between flaperon and the wingtip and, while moving the flaperon back and forth in the axial direction, measure the free play.		Figure 27-014

CAUTION: The maximum permissible amount of axial flaperon free play is 0.5 mm.



Figure 27-014
Flaperon axial free play check

27-50: 2.1.4. Radial free play check

Reference: Figure 27-015

Step	Action	Required parts, materials and tools	Reference
1	Remove the wings.	Vernier caliper	57-10
2	Place Vernier caliper between flaperon and the wingtip and, while moving the flaperon back and forth in the radial direction, measure the free play.		Figure 27-015

CAUTION: The maximum permissible amount of radial rudder free play is 0.5 mm.

27-50
FLAPERONS



Figure 27-015
Flaperon radial free play check

27-50: 2.2. Vertical flaperon pushrods

27-50: 2.2.1. Inspection/check

Step	Action	Required parts, materials and tools	Reference
1	Remove the crew seats.		25-10
2	Remove aft battery box.		24-30: 2.1.1.
3	Remove aft battery bay.		
4	Carry out visual inspection of the vertical flaperon pushrods.		05-20
5	Carry out operational inspection of the vertical flaperon pushrods.		05-20
6	Lubricate pushrod bearings.		12-20
7	Install aft battery bay.		24-30
8	Install aft battery box.		24-30: 2.1.2.
9	Install the crew seats.		25-10

27-50: 2.3. Upper flaperon bellcranks

27-50: 2.3.1. Inspection/check

Reference:

Step	Action	Required parts, materials and tools	Reference
1	Carry out visual inspection of the upper flaperon bellcranks.		05-20
2	Carry out operational inspection of the upper flaperon bellcranks.		05-20

27-50: 2.3.2. Inspection/check

Reference:

Step	Action	Required parts, materials and tools	Reference
1	Remove wings.		57-10: 2.1.1.
2	Carry out visual inspection of the upper flaperon bellcrank clutch.		05-20
3	Clean and lubricate the upper flaperon bellcrank clutch.		12-20
4	Install wings.		57-10: 2.1.2.
5	Carry out operational inspection of the flaperons.		05-20

27-50: 2.4. Flaperon bellcrank assembly

27-50: 2.4.1. Inspection/check

Step	Action	Required parts, materials and tools	Reference
1	Remove the crew seats.		25-10
2	Remove aft battery box.		24-30: 2.1.1.
3	Remove aft battery bay.		
4	Remove control stick boot.		25-10
5	Carry out visual inspection of the flaperon bellcrank assembly.		
6	Carry out operational inspection of the flaperon bellcrank assembly.		05-20
7	Lubricate bearings.		12-20
8	Install aft battery bay.		24-30
9	Install aft battery box.		24-30: 2.1.2.
10	Install the crew seats.		
11	Install control stick book.		25-10

27-50: 2.4.2. Major inspection

Step	Action	Required parts, materials and tools	Reference
1	Remove the control stick boots.	Phillips screw-driver	25-10
2	Remove the crew seats.		24-30: 2.1.1.
3	Remove aft battery box.		
4	Remove aft battery bay.		
5	Use borescope to carry out visual inspection of the flaperon bellcrank assembly sticks.		05-20
6	Install aft battery bay.		24-30
7	Install aft battery box.		24-30: 2.1.2.
8	Install the crew seats.		
9	Install control stick book.		25-10

27-50
FLAPERONS

27-50: 2.5. Flaperon handle assembly

27-50: 2.5.1. Inspection/check

Reference:

Step	Action	Required parts, materials and tools	Reference
1	Remove the crew seats.	Phillips screwdriver	25-10
2	Remove aft battery box.		24-30: 2.1.1.
3	Remove aft battery bay.		
4	Carry out visual inspection of the flaperon handle assembly.		05-20
5	Carry out operational inspection of the flaperon handle assembly.		
6	Lubricate bearing.		12-20
7	Install aft battery bay.		24-30
8	Install aft battery box.		24-30: 2.1.2.
9	Install the crew seats.		25-10

31

CHAPTER 31 – INDICATING/RECORDING SYSTEMS

TABLE OF CONTENTS

SECTION	SUBJECT	PAGE NUMBER
31-00	GENERAL	31-03
31-10	INSTRUMENT AND CONTROL PANELS Description Maintenance Practices	31-04

31-00 GENERAL

This chapter describes the ALPHA Electro's indicating/recording system. The instrument panel and the caution/warning system are also covered in this chapter.

31-10
INSTRUMENT AND CONTROL
PANELS

31-10 INSTRUMENT AND CONTROL PANELS

1. Description

The instrument panel is equipped with various instruments/gauges that indicate airspeed, altitude, RPM, etc.. Depending on whether the aircraft has a US or NON-US instrument configuration, options include: artificial horizon, EPSI 570 electric system parameters (monitors RPM, power controller temperature, motor temperature, coolant temperature, state of charge, battery temperature and state of health), radio F.U.N.K.E. ATR833 or Garmin GTR200, transponder Filser TRT800A or Garmin GTX335 and the GPS Garmin AERA 660. Instructions on how to use the instruments/gauges (COM, GPS) are found in individual equipment manuals, which are to be considered supplement to this POH. The gauges are round and 80 mm or 57 mm in diameter, while the GPS has a touchscreen. The radio is a modern lightweight unit, features full VOX intercom and dual PTT connections.

The cockpit electrical system panel incorporates a separate master switch, avionics switch, separate power enable and throttle enable switches. There are fuses located in the illuminated rectangular toggle switches, which are wired behind the avionics switch to each of the electrical avionics loads.

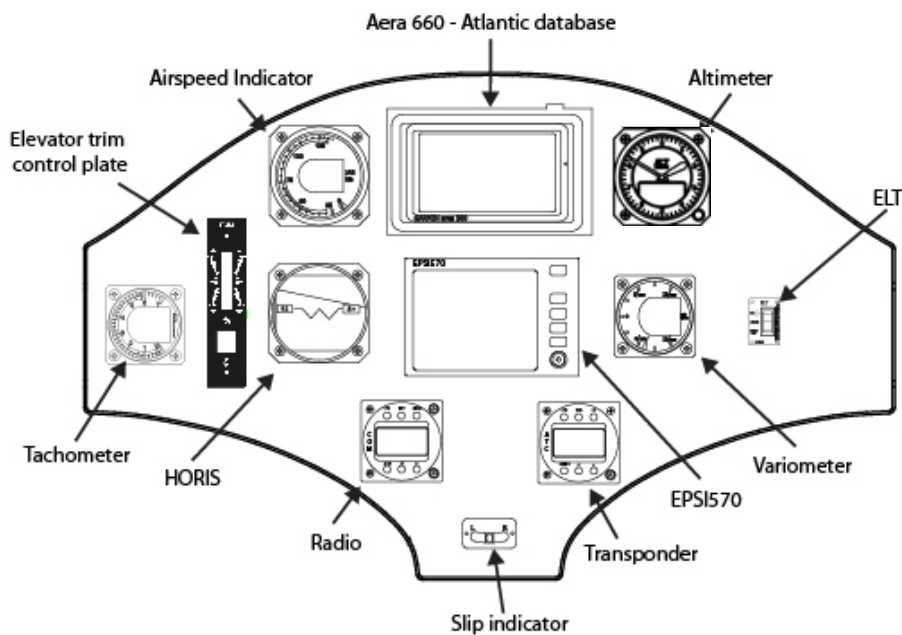

Figure 31-001
NON US Instrument panel configuration

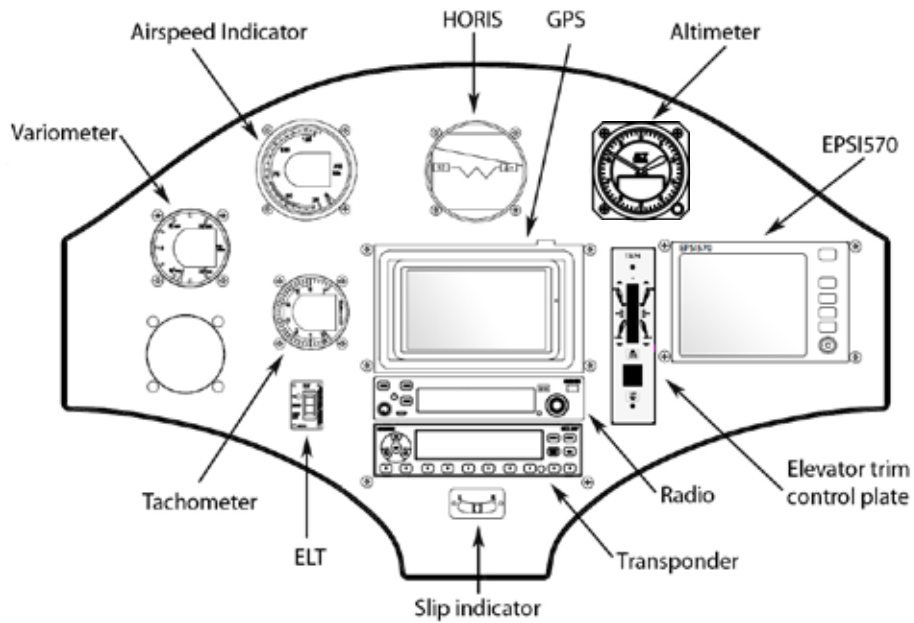

Figure 31-002
US Instrument panel configuration

2. Maintenance Practices

31-10: 2.1. Front panel

31-10: 2.1.1. Inspection/check

Step	Action	Required parts, materials and tools	Reference
1	Carry out visual inspection of the panel's structure.		05-20
2	MASTER switch off, AVIONICS switch off.		
3	Disconnet the battery boxes.		24-30: 2.1.3.
4	Carry out visual and operational inspection of all the panel's instruments/knobs. Check for any damage or wear.		05-20
5	Connect the battery boxes.		

31-10 INSTRUMENT AND CONTROL PANELS

31-10: 2.2. Instrument panel cover

31-10: 2.2.1. Removal

Step	Action	Required parts, materials and tools	Reference
1	MASTER switch off, AVIONICS switch off.	- torx screwdriver set - Phillips screwdriver (standard + stubby)	
2	Disconnect the battery the battery boxes.		
3	Unscrew/remove all of the torx and self-tapping screws securing the cover to the instrument panel/fuselage.		
4	Lift cover and disconnect the Garmin G26C gps antenna and the compass' lighting cable.		
5	Remove the instrument panel cover.		

31-10: 2.2.2. Installation

Reference:

Step	Action	Required parts, materials and tools	Reference
1	Position the cover on the instrument panel.	- torx screwdriver set - Phillips screwdriver (standard + stubby)	05-20
2	Lift cover and connect the Garmin G26C gps antenna and the compass' lighting cable.		
3	Fasten the cover to the instrument panel/fuselage using the torx and self-tapping screws.		
4	Carry out visual inspection.		
5	Carry out operational inspection of the Garmin G26C gps antenna and the compass light.		
6	Connect the battery boxes.		

31-10: 2.3. Switch panel

31-10: 2.3.1. Removal

Step	Action	Required parts, materials and tools	Reference
1	MASTER switch off, AVIONICS switch off.	- torx screwdriver set	
2	Remove all of the torx screws securing the switch panel to the instrument panel pedestal.		
3	Carefully dislodge the panel and move it away from the pedestal.		

31-10: 2.3.2. Installation

Step	Action	Required parts, materials and tools	Reference
1	MASTER switch off, AVIONICS switch off.	- torx screwdriver set	
2	Carefully slide the panel into place on the pedestal.		
3	Fasten it to the pedestal using torx screws.		

PIPISTREL

This page is intentionally left blank.

32

CHAPTER 32 – LANDING GEAR

TABLE OF CONTENTS

SECTION	SUBJECT	PAGE NUMBER
32-00	GENERAL	32-03
32-10	MAIN GEAR	32-04
	Description Maintenance Practices	
32-20	NOSE GEAR	32-07
	Description Maintenance Practices	
32-40	WHEELS AND BRAKES General	32-09
32-41	WHEELS	32-10
	Description Maintenance Practices	
32-42	BRAKES	32-12
	Description Maintenance Practices	
32-50	STEERING	32-14
	Description Maintenance Practices	

32-00 GENERAL

This chapter describes those units and components which furnish a means of supporting and steering the airplane. The tricycle-type landing gear consists of a composite, basalt fiber strut that's bolted to the airframe structure and provides adequate shock absorption, as well as a steerable nose gear strut, which is of tubular aluminum construction, has an oleo shock absorber and is integrated into the motor mount.

The main wheels have hydraulically operated brakes actuated by a brake lever located in the central console of the cabin. The nose landing gear is steerable, connected to the pedals and incorporates an oil-spring damper element. The brake system consists of a single disc brake assembly on each main landing gear wheel, hydraulic fluid reservoir, associated hydraulic plumbing and brake lever with parking brake feature incorporated (See Figure 32-001).

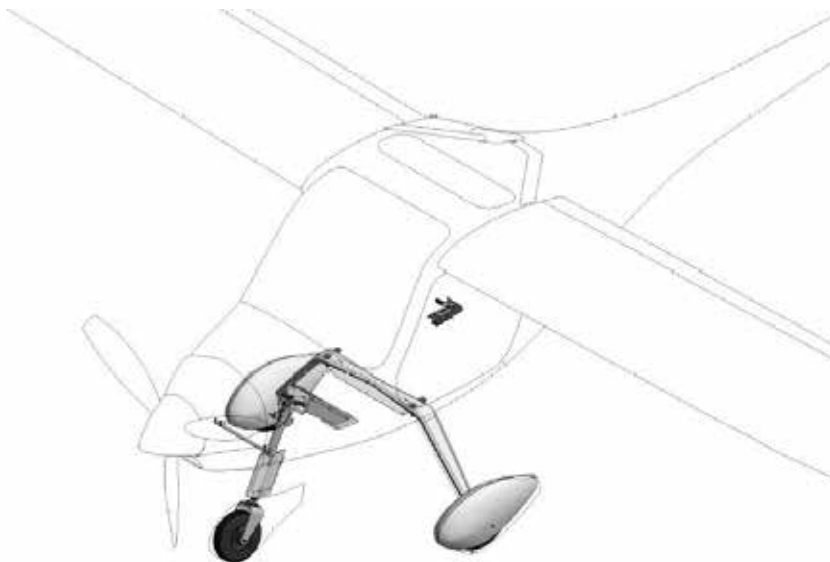

Figure 32-001
Landing Gear

32-10
MAIN GEAR**32-10 MAIN GEAR****1. Description**

The MLG strut is made of basalt fiber and has two parallel elements that produce a semi-redundant structure that allows for predictable stress point locations. The strut is composed by two parallel elements producing a semi-redundant structure and allowing for predictable locations of stress points. During normal landing and taxi operations, the main gear legs act as primary shock absorbing units and provide support for majority of aircraft weight. The strut is directly attached to the bottom side of the cabin floor by four bolts (see Figure 32-002).



Figure 32-002
Main Landing Gear Installation

2. Maintenance Practices

32-10: 2.1. Main landing gear strut

32-10: 2.1.1. Inspection/check

Reference:

Step	Action	Required parts, materials and tools	Reference
1	Remove the main wheel fairings.		32-10
2	Remove MLG strut cover.		
3	Carefully inspect the entire strut for any signs of damage. Pay particular attention to where the strut is in contact with the fuselage and where the wheels are fastened to it. Look for any wear, chips, signs of delamination or cracks similar to the one in Figure.		Figure 32-003
CAUTION: Any damage incurred by the main landing gear strut can be a safety hazard and must be reported to Pipistrel.			
4	Install MLG strut cover.		
5	Install main wheel fairings.		32-10



Figure 32-003
Example of a damaged MLG strut

32-10
MAIN GEAR

32-10: 2.2. MLG fairings

32-10: 2.2.1. Removal

Reference:

Step	Action	Required parts, materials and tools	Reference
1	Remove the hex head bolt securing the fairing to the fairing spacer.	- T-handle hex head screwdriver set, - Torx screwdriver set	
2	Remove the six screws securing the fairing to the fairing plate.		
3	Remove fairing.		

32-10: 2.2.2. Installation

Reference:

Step	Action	Required parts, materials and tools	Reference
1	Position the spacer over the wheel and main landing gear strut.	- T-handle hex head screwdriver set, - Torx screwdriver set - Loctite 243	
2	Apply Loctite to the hex head bolt's thread.		
3	Install fastening material to finger tight.		

NOTE: Make sure there is adequate clearance between the fairing and other landing gear components.

4	Tighten fastening material.		
---	-----------------------------	--	--

32-20 NOSE GEAR

1. Description

The nose gear strut assembly consists of a tubular strut attached to the motor mount. The free casting nose wheel's maximum turning arc is 45 degrees either side of center. Shock absorption is provided by a nitrogen and hydraulic fluid filled oleo-pneumatic strut in which compression of a piston rod reacts against the motor mount.

2. Maintenance Practices

32-20: 2.1. Nose landing gear fairing

32-20: 2.1.1. Removal

Step	Action	Required parts, materials and tools	Reference
1	Prop the nose landing gear up by weighing down the tail cone.	- metric wrench set - T-handle hex head screw-driver set - T-handle socket wrench set	07-20
2	Remove white tape securing fairing cover to fairing.		
3	Remove fairing cover.		
4	Remove the fastening material securing the fairing/wheel to nose landing gear.		
5	Remove nose wheel.		
6	Remove fastening material securing the fairing/nose wheel fork to the nose landing gear.		
7	Remove fairing.		

32-20: 2.1.2. Installation

Step	Action	Required parts, materials and tools	Reference
1	Prop the nose landing gear up by weighing down the tail cone.	- metric wrench set - T-handle hex head screw-driver set - T-handle socket wrench set - Loctite 243	07-10
2	Position the nose wheel fork and fairing on the nose landing gear.		
3	Apply Loctite 243 to the locknuts.		
4	Fasten the nose wheel fork and fairing to the nose landing gear.		
5	Position nose wheel in fairing/fork.		
6	Apply Loctite 243 to nose wheel axle nut.		
7	Fasten nose wheel in place and tighten nut.		

NOTE: After installing the wheel make sure there is adequate clearance between it and the other nose gear components. Make sure that the wheel turns freely and isn't hindered by anything.

continued on the next page

32-20
NOSE GEAR

Step	Action	Required parts, materials and tools	Reference
8	Install nose landing gear fairing cover.		
9	Apply tape to secure cover.		
10	Remove counterweight from tail cone and lower front end of aircraft.		

32-20: 2.2. Nose landing gear

32-20: 2.2.1. Inspection/check

Step	Action	Required parts, materials and tools	Reference
1	Remove the nose landing gear fairing.	<ul style="list-style-type: none"> - metric wrench set, - T-handle hex head screwdriver set, - T-handle socket wrench set - Loctite 243 	32-20
2	Inspect nose landing gear strut for any signs of damage, such as deformation, cracks or corrosion.		
3	Inspect the nose landing gear fork for any signs of damage, such as deformation, cracks or corrosion.		
4	Grab the propeller with both hands, block the nose wheel with your foot and lean back. Inspect the movement of the nose landing gear's shock absorber. Make sure it's movement is smooth and unhindered.		
5	Inspect the shock absorber for any signs of impact damage or wear.		
6	Inspect the nose landing gear's turning range. Confirm that it's movement is unhindered and smooth. Also confirm that the nose landing gear's bellcrank is in good working condition and moves freely.		
7	Install nose landing gear fairing.		32-20

32-40 WHEELS AND BRAKES

General

This chapter describes the ALPHA Electro's wheel and brakes system. This system allows is what allows the aircraft to roll along the ground while taxiing and stop when needed.

32-41
WHEELS

32-41 WHEELS

1. Description

Beringer Wheel assembly and Tires

The main wheels on the Virus SW167 are 6 inches in diameter, tubeless and manufactured by Beringer. They are made from high strength aluminum alloy, machined solid on CNC and anodized for optimal corrosion resistance. The wheel is secured to the axle with a nut, and cotter pin.

Nose Wheel and Tire

The nose wheel is of aluminum construction and designed for tires with inner tubes. The 4.00 x 4 wheels use a 6-ply-rated tube tire and rotate on two bearings protected against contamination by grease seals. The free caster wheel is installed on an independent axle and is used to steer the airplane on the ground by means of differential brake application.

2. Maintenance Practices

32-41: 2.1. Main landing gear wheels

32-41: 2.1.1. Removal

Step	Action	Required parts, materials and tools	Reference
1	Remove main landing gear fairings.	- metric wrench set - cutting nippers - M25 slotted nut key (P/N 1190113) - landing gear stand (P/N 1190264)	32-10
2	Remove fairing spacer.		07-10: 2.1.1.
3	Prop MLG strut up with landing gear stand.		
4	Cut/remove wheel locking wire.		
5	Remove M25 slotted nut.		
6	Slide wheel off axle.		

32-41: 2.1.2. Installation

Step	Action	Required parts, materials and tools	Reference
1	Position wheel on axle and brake disc.		
2	Fasten wheel to axle using M25 slotted locknut. Tighten until the nut comes into contact with the wheel's bearing. Torqueing is NOT required!	- metric wrench set, - 1 mm locking wire, - M25 slotted nut key (P/N 1190113)	
WARNING:	Never reuse this, or any other locknut after removing it. Always replace it with a new one!		
WARNING:	After installing the wheel make sure there is no play between it and the axle. Make sure that the wheel turns freely and isn't hindered by anything.		
3	Positive lock the brake disc with locking wire.	- landing gear stand (P/N 1190264)	
4	Remove landing gear stand.		
5	Install main landing gear fairings.		32-10

32-41: 2.1.3. Inspection/check

Please refer to [1].

32-41: 2.1.4. MLG Tire removal

Step	Action	Required parts, materials and tools	Reference
1	Remove MLG wheel.		32-41: 2.1.1.
2	Deflate tire pressure to zero.		
3	Remove M6 bolts securing wheel half.		
4	Remove O-ring.		
5	Slide tire off wheel.		

32-41: 2.1.5. MLG Tire installation

Step	Action	Required parts, materials and tools	Reference
1	Slide new tire on wheel.		
2	Install new O-ring.		
3	Secure wheel half using M6 bolts.		
4	Replenish with compressed air to the required pressure.	- metric wrench set - cutting nippers - M25 slotted nut key (P/N 1190113) - Landing gear stand (P/N 1190264)	Table 12-001
5	Install MLG wheel.		32-41: 2.1.2.

32-41
WHEELS

2.2. Nose landing gear wheel

32-41: 2.2.1. Removal/installation – see 32-20

32-41: 2.2.2. Tire/inner tube change

Step	Action	Required parts, materials and tools	Reference
1	Remove nose landing gear fairing/wheel.	- metric wrench + socket set - T-handle hex head screw-driver set - Loctite 243	32-20
2	Deflate tire/tube.		
3	Remove the fastening material holding the wheel's two halves together.		
4	Remove both halves of the wheel.		
5	Pull inner tube out of tire.		
6	Inspect both the tire and tube for any signs of damage/wear. Replace if necessary.		
7	Reassemble following the steps above in the reverse order. Apply Loctite 243 to the nuts' thread before torquing.		
8	Replenish tire air.		12-10: 2.2

32-42 BRAKES

1. Description

The brake system consists of a dual piston single disc brake assembly on each main landing gear wheel, master cylinder for each rudder pedal, hydraulic fluid reservoir, parking brake, and associated hydraulic plumbing.

The hydraulically operated brakes are individually activated by floor mounted toe pedals located at both pilot stations. The master cylinders are located forward of the pilot's rudder pedals. The reservoir is serviced with DOT 3 or DOT 4 hydraulic fluid.

The parking brake mechanism holds induced hydraulic pressure on the disc brakes for parking. It's control lever can be found on the cabin floor, on the port side of the instrument panel's pedestal.



Figure 32-004
Hand brake

2. Maintenance Practices

32-42: 2.1. Hydraulic brake lines

32-42: 2.1.1. Assembly/disassembly

Please refer to [1].

32-42: 2.1.2. Inspection/check

Step	Action	Required parts, materials and tools	Reference
1	Remove the main wheel fairings.	- T-handle hex head screwdriver set - Torx screwdriver set	32-10
2	Inspect brake lines where they exit the main landing gear strut and attach to the brake system. Check for signs of chafing, wear and damage.		
3	Do the same for all of the hydraulic brake lines that are accessible in the cabin.		

32-42
BRAKES

32-42: 2.2. Brake pads

32-42: 2.2.1. Inspection/check (Beringer type)

Step	Action	Required parts, materials and tools	Reference
1	Remove main landing gear fairing.		32-10
2	Remove main landing gear wheel.		32-41
3	Inspect brake pads for signs of wear, scoring and/or overheating.		
4	Measure brake pad thickness and compare it to the maximum permissible wear found in [1].		

32-42: 2.2.2. Removal/installation

Please refer to [1].

32-42: 2.2.3. Brake pads inspection/check (Pipistrel type)

Reference:

Step	Action	Required parts, materials and tools	Reference
1	Remove main landing gear fairing.	- Vernier caliper	32-10
2	Remove main landing gear wheel.		32-41
3	Remove and inspect brake discs for signs of wear, scoring and/or overheating.		
4	Measure brake disc thickness on each of the eight protrusions using a Vernier caliper.		

WARNING: If you get an average measurement of 2mm or less, the brake pad must be replaced with a new one. A measurement of 1.5 mm is the bare minimum and a safety hazard!

32-42: 2.2.4. Removal/installation (Pipistrel type)

Step	Action	Required parts, materials and tools	Reference
1	Remove main landing gear fairing.		32-10
2	Remove main landing gear wheel.		32-41
3	Remove from the wheel axle the brake shoe unscrewing the three M6 screws		
4	Open the brake shoe, unscrewing the three M8 screws. Check the two brake pistons and replace them if necessary.		
5	Remount the assembly following the steps above in reverse order.		

32-42: 2.3. Brake discs

32-42: 2.3.1. Inspection/check (Beringer type)

Step	Action	Required parts, materials and tools	Reference
1	Remove main landing gear fairing.		32-10
2	Remove main landing gear wheel.		32-41
3	Inspect brake discs for signs of wear, scoring and/or over-heating.		
4	Measure brake disc thickness and compare it to the maximum permissible wear found in [1].		

32-42: 2.3.2. Removal/installation (Beringer type)

Please refer to [1] for Beringer's wheels. Once the safety wire has been cut during the wheel removal, the wheel disc is already separated from the wheel (see 32-41: 2.1.1.)

32-42: 2.3.3. Inspection/check (Pipistrel type)

Reference:

Step	Action	Required parts, materials and tools	Reference
1	Remove main landing gear fairing if present.		32-10
2	Remove main landing gear wheel.		32-41: 2.1.3.
3	Once the wheel has been removed, the brake disk is visible on the inner face of the wheel hub.		
4	Examine the heads of the three bolts holding the disc in place. If the material of the disc has been consumed till the bolt's head, the disc must be replaced.		

32-42: 2.3.4. Brake discs Removal/installation (Pipistrel type)

Step	Action	Required parts, materials and tools	Reference
1	Locate the three M5 Hexagon socket head cap screw holding the disc in place on the inner face of the wheel.	- Allen key set - Loctite 243	32-42: 2.3.3.
2	Remove the screws and the disc.		
3	Replace the disc and fix it to the wheel applying Loctite 243 to the screws.		

32-42
BRAKES

32-42: 2.4.2. Brake circuit bleeding procedure - hand brake version (Standard/Beringer wheels)

Step	Action	Required parts, materials and tools	Reference
1	Connect on the nipple fitting on the right brake a silicon hose of about 30 cm of lenght.	- Wrench set - Alen key set - Pliers	
2	Pump the hand brake several times, in order to build up pressure on the system.	- Extra brake fluid	
3	Take a small cup and place it near the right wheel.		
4	Release the nut at the base of the nipple, on the right brake. Collect into the cup the fluid that drips out from the hose.		
5	Repeat the steps (x) and (y) two or more times, until no air bubbles remain in the line.		
6	Screw and close the nipple nut and detach the silicon hose from the brake pad.		
7	Refill the system from the cabin reservoir.		
8	Repeat the steps from (1) to (6) for the left wheel brake line.		
9	Refill the system again with hydraulic fluid from the cabin reservoir.		
10	Perform functional test of the brake system.		

32-50 STEERING

1. Description

The nose gear is steerable. It is connected to the rudder pedal control system by a bellcrank and a set of cables/springs (see Figure 32-007).

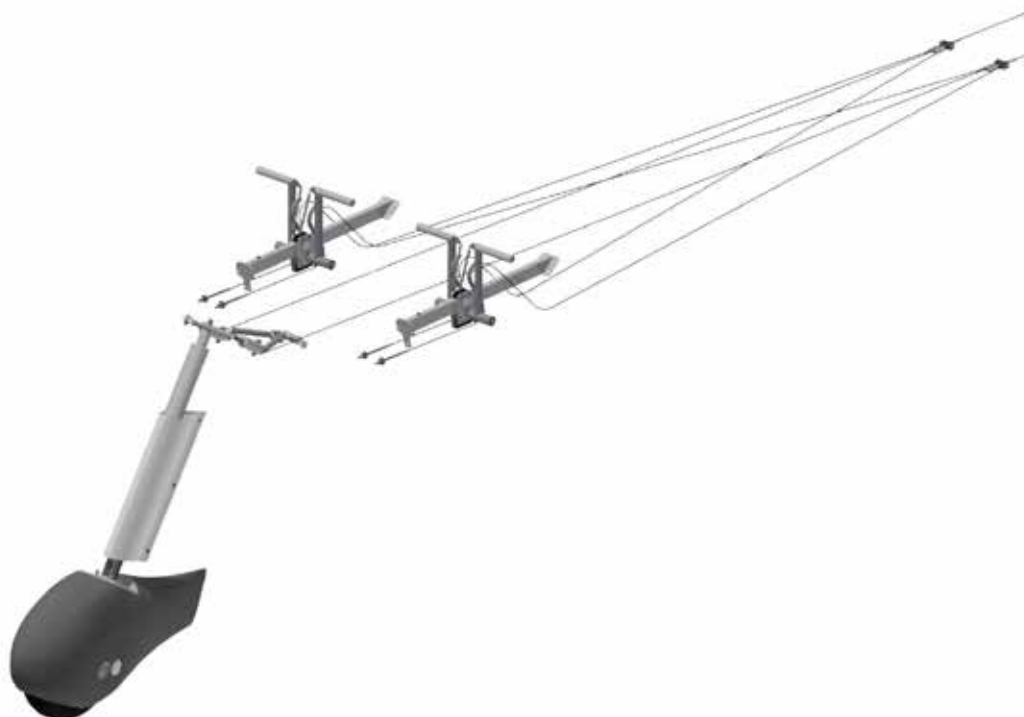

Figure 32-007
Steering System

32-50
STEERING

2. Maintenance Practices

32-50: 2.1. Steering bellcrank

32-50: 2.1.1. Inspection/check

Step	Action	Required parts, materials and tools	Reference
1	Remove the nose landing gear fairing.		32-20
2	Inspect the nose landing gear's turning range. Confirm that it's movement is unhindered and smooth.		
3	Confirm that the nose landing gear's bellcrank is in good working condition and moves freely.		
4	Confirm that the nose landing gear's oil-spring damping element is in good working condition and moves freely.		
5	Install nose landing gear fairing.		32-20

33

CHAPTER 33 – LIGHTS

TABLE OF CONTENTS

SECTION	SUBJECT	PAGE NUMBER
33-00	GENERAL	33-03
33-10	FLIGHT COMPARTMENT	33-04
	Description Maintenance Practices	
33-40	EXTERIOR LIGHTING	33-05
	Description Maintenance Practices	

33-00 GENERAL

This chapter contains information about the interior and exterior lighting systems used on the ALPHA Electro. Exterior lighting consists of standard wing tip navigation lights with integral anti-collision strobe lights. The separately controlled landing light, which also serves as the taxi light, is located on the bottom motor cowling. All lights incorporate LED technology.

Interior lighting consists of a separately controlled, incandescent overhead light for general cabin lighting.

33-10
FLIGHT
COMPARTMENT

33-10 FLIGHT COMPARTMENT

1. Description

A cabin flood-light is present and illuminates the master electrical panel and circuit breakers. It is located just above the crew seats, fastened to the cabin bulkhead.

2. Maintenance practices

33-10: 2.1. Flight compartment

33-10: 2.1.1. Inspection/check

Step	Action	Required parts, materials and tools	Reference
1	Carry out visual inspection of all the flight compartment lights.		05-20
2	Carry out operational inspection of all the flight compartment lights.		05-20
3	Replace if necessary.		

NOTE: Refer to chapter 91-00 for the wiring diagrams that pertain to all of the flight compartment lights.

33-40 EXTERIOR LIGHTING

1. Description

The ALPHA Electro comes equipped with NAV/STROBE lights located on the wingtips and a LED landing light fastened to the bottom motor cowling.

Navigation Lights

These lights are controlled by the NAV/STROBE light switch on the switch panel. 12 VDC for navigation light operation is supplied through the NAV/STROBE light switch, which includes a resettable circuit breaker element (see Figure 33-001).

Strobe Light

Anti-collision strobe lights are integrated into the standard navigation light and controlled by the same switch.



Figure 33-001
NAV/STROBE light installation

Landing Light

A High Intensity LED landing light is mounted in the lower cowling. The landing light is controlled through the LDG light switch on the switch panel. 12 VDC for navigation light operation is supplied through the LDG light switch, which includes a resettable circuit breaker element. The landing light has thermal protection built in and its operation is not time limited (see Figure 33-002).

33-40
EXTERIOR
LIGHTING



Figure 33-002
Landing light installation

2. Maintenance Practices

33-40: 2.1. NAV/STROBE lights

33-40: 2.1.1. Inspection/check

Reference: Figure 33-001

Step	Action	Required parts, materials and tools	Reference
1	Carry out visual inspection of the NAV/STROBE lights.		05-20
2	Carry out operational inspection of the NAV/STROBE lights.		
3	Replace if necessary.		

33-40: 2.2. NAV/STROBE lights

33-40: 2.2.1. Inspection/check

Step	Action	Required parts, materials and tools	Reference
1	Carry out visual inspection of the landing light.		05-20
2	Carry out operational inspection of the landing light.		
3	Replace if necessary.		

NOTE: Refer to chapter 91-00 for the wiring diagrams that pertain to all of the external lights.

33-40: 2.3. LANDING light

33-40: 2.3.1. Removal

Step	Action	Required parts, materials and tools	Reference
1	Locate landing light on lower cowling.	- Torx screwdriver set	
2	Disconnect landing light cable from connector.		
3	Remove screws and washers connecting landing light to lower cowling.		
4	Disconnect and remove the old landing light.		

33-40: 2.3.2. Installation

Step	Action	Required parts, materials and tools	Reference
1	Position new landing light into lower cowling.	- Torx screwdriver set - Loctite 243	
2	Run the new landing light cable through the hole in the fuselage.		
3	Apply Loctite 243 to the bolts' thread.		
4	Tighten screws and washers connecting landing light to lower cowling.		
5	Fasten the new landing light to the fuselage.		
6	Fit connector to cable.		
7	Connect landing light to existent wire harness.		
8	Adjust landing light position. The angle between the light axes and the lower cowling is 20°.		

NOTE: white wire is "+", white with blue stripe is "-".

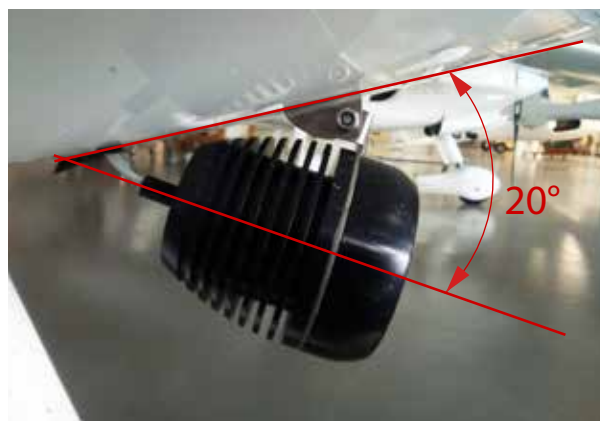

Figure 33-003
Landing light adjustment

PIPISTREL

This page is intentionally left blank.

34

CHAPTER 34 – NAVIGATION AND PITOT-STATIC SYSTEMS

TABLE OF CONTENTS

SECTION	SUBJECT	PAGE NUMBER
34-00	GENERAL	34-03
34-10	FLIGHT ENVIRONMENTAL SYSTEMS	
	Description	34-04
	Maintenance Practices	

34-00 GENERAL

The chapter describes the navigation systems used on the ALPHA Electro. It covers components such as the pitot-static system, indicators, positioning systems and landing aids.

34-10
FLIGHT ENVIRONMENTAL
SYSTEMS**34-10 FLIGHT ENVIRONMENTAL SYSTEMS****1. Description**

This chapter discusses all of the equipment/instruments on the ALPHA Electro that collect data from the environment and convert it into usable information for the pilot. This includes the pitot-static system, outside air temperature sensor, vertical speed indicator, altimeter and airspeed indicator.

Pitot-Static system

The pitot-static system consists of a single pitot tube mounted on the starboard wing, approximately 3 meters from fuselage (see Figure 34-001). The lines run through the wings, down the fuselage, under the seat pan and into the instrument panel, where the mechanical airspeed indicator and altimeter are located.



Figure 34-001
Pitot tube installation

Outside Air Temperature

The outside air temperature sensor (OAT) is mounted to the fuselage just aft of the port side wing (see Figure 34-002). It provides the PFD/MFD with data in degrees Celsius (°C).



Figure 34-002
OAT sensor installation

Airspeed indicator

Indicated airspeed is shown on an internally lit precision airspeed indicator installed on the pilot's instrument panel. The instrument measures the difference between static and Pitot pressure, and displays the result in knots on an airspeed scale.

Altimeter

Airplane altitude is depicted on a conventional, three-pointer, internally-lit barometric altimeter. The instrument senses the local barometric pressure adjusted for altimeter setting and displays the result on the instrument in feet. The altimeter is calibrated for operation between -1000 and 20,000 feet altitude. The scale is marked from 0 to 10 in increments of 2. The long pointer indicates hundreds of feet and sweeps the scale every 1000 feet (each increment equals 20 feet). The short, wide pointer indicates thousands of feet and sweeps the scale every 10,000 feet (each increment equals 200 feet). The short narrow pointer indicates tens of thousands feet and sweeps from 0 (zero) to 2 (20,000 feet with each increment equal to 2000 feet). Barometric windows on the instrument's face allow barometric calibrations in either inches of mercury (in.Hg) or millibars (mb). The barometric altimeter settings are input through the barometric adjustment knob at the lower left of the instrument.

34-10
FLIGHT ENVIRONMENTAL
SYSTEMS

2. Maintenance Practices

34-10: 2.1. Pitot tube

34-10: 2.1.1. Inspection/check

Reference: Figure 34-001

Step	Action	Required parts, materials and tools	Reference
1	Locate the pitot tube fastened to the bottom surface of the starboard wing.		
2	Carry out visual inspection. Make sure the wing's composite structure around the tube's mounting flange hasn't incurred any damage.		05-20

34-10: 2.1.2. Removal

Reference: Figure 34-001

Step	Action	Required parts, materials and tools	Reference
1	Locate the pitot tube fastened to the bottom surface of the starboard wing.	- T-handle hex head screwdriver set	
2	Unscrew/remove the screws securing the Pitot tube to the wing.		
3	Pull the Pitot tube away from the wing slightly to access the hose ports.		
4	Disconnect the hoses from the tube.		
5	Remove the Pitot tube.		
6	Carry out visual inspection of the Pitot tube and hoses.		05-20

34-10: 2.1.3. Installation

Reference: Figure 34-001

Step	Action	Required parts, materials and tools	Reference
1	Attach hoses to the Pitot tube.	- T-handle hex head screwdriver set	
2	Position the Pitot tube on the wing's bottom surface.		
3	Fasten the Pitot tube to the wing.		

CAUTION: Install the Pitot tube so that it's parallel to the aircraft's longitudinal axis, therefore, pointing in the direction of flight. The readings given by navigation instruments on the ALPHA Electro will not be accurate if it's installed at an angle.

WARNING: Do not blow into the Pitot tubes entry ports as this could easily damage the instruments.

51

CHAPTER 51 – STANDARD PRACTICES - STRUCTURES

TABLE OF CONTENTS

SECTION	SUBJECT	PAGE NUMBER
51-00	GENERAL	51-03
51-10	DETECTING/ASSESSING COMPOSITE DAMAGE Description Maintenance Practices	51-04

51-00 GENERAL

This chapter covers all the maintenance procedures that pertain to the ALPHA Electro's structure. The airframe is a complex composite structure that needs to be checked periodically for signs of wear and damage. Damage to composite components can be difficult to detect, but some simple techniques can make it easier.

51-10
DETECTING/ASSESSING
COMPOSITE DAMAGE**51-10 DETECTING/ASSESSING COMPOSITE DAMAGE****1. Description**

Composite damage comes in many forms and is sometimes difficult to detect. The most common is impact damage, such as dents or punctures. These, as well as scratches and gouges, can usually be detected by visually inspecting the component. Other types of damage however, such as delamination, which are sometimes just as critical as other forms of damage, can go easily go undetected. That is why thorough inspection of the ALPHA Electro's airframe is advisable and needed in order to keep the aircraft in good working condition and its occupants safe.

2. Maintenance Practices**51-10: 2.1. Visual inspection of composite components**

Light is an excellent visual inspection aid. Place the composite component, whether big or small, in a well lit space and move it slowly so that the light reflects off it at different angles. Any bends, warping and/or dents should be detectable by using this technique. Once detected, the extent of the components damage needs to be assessed.

51-10: 2.2. Tap test

Composite components are known for mechanical strong and robust, yet very light. Their underlying structure must remain intact in order to ensure good mechanical properties. Any damage that it incurs, however, can easily go undetected, because it's not visible.

One way of a detecting interior composite damage, or determining the extent of damage already incurred, is a tap test. This is to be carried out with a hard, metallic object, such as a coin. To avoid damaging the composite test specimen, be sure to use an object that isn't sharp or pointed. Simply tap the surface of the composite component with the blunt, metallic object and listen to the sound this produces. Areas that are undamaged typically sound sharp and clear, whereas areas that have suffered delamination or disband, sound hollow and/or flat.

Any damage to the major bonding lines of the ALPHA Electro's structural components can also be detected by the tap test described above. The following bonding lines, clearly depicted in Figures 51-001 to 51-004, are to be considered major:

- Upper fuselage/vertical stabilizer bonding line
- Lower fuselage bonding line
- Wing leading edge bonding line
- Horizontal stabilizer leading edge bonding line

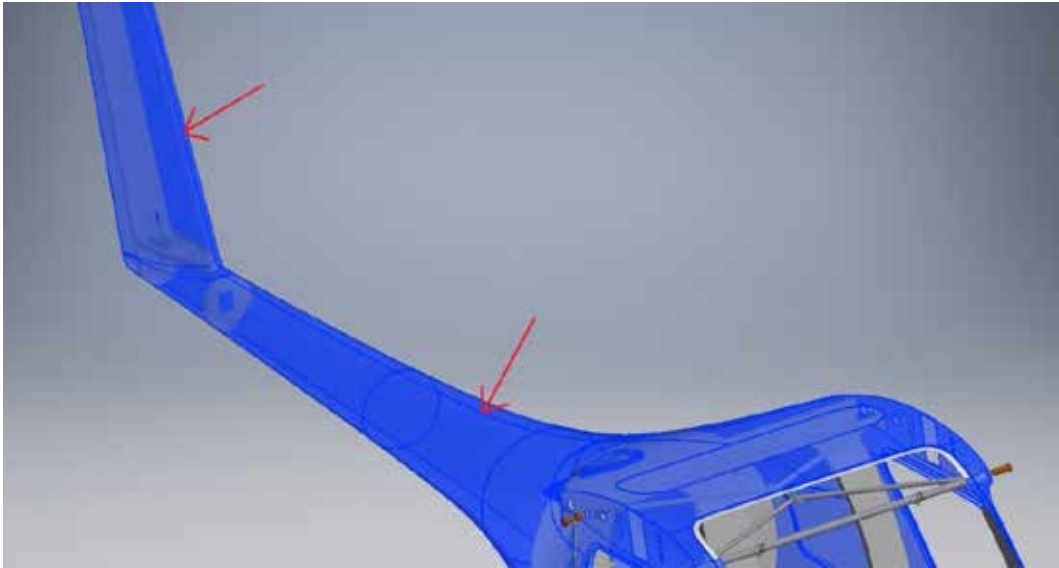

Figure 51-001
Upper fuselage/vertical stabilizer bonding line

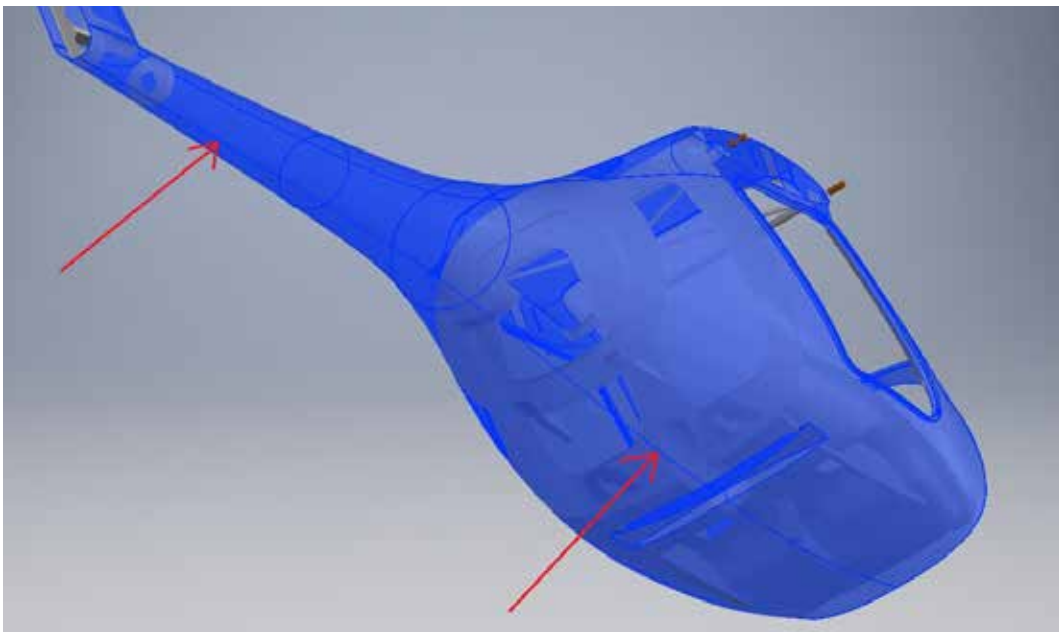

Figure 51-002
Lower fuselage bonding line

51-10
DETECTING/ASSESSING
COMPOSITE DAMAGE

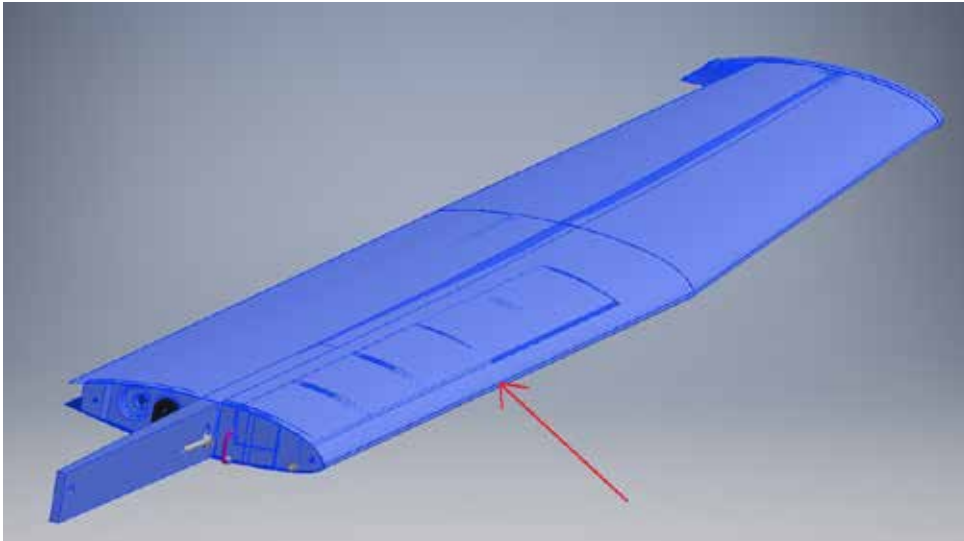

Figure 51-003
Wing leading edge bonding line



Figure 51-004
Horizontal stabilizer leading edge bonding line

52

CHAPTER 52 – DOORS

TABLE OF CONTENTS

SECTION	SUBJECT	PAGE NUMBER
52-00	GENERAL	52-03
52-10	PASSENGER AND CREW DOORS	52-04
	Description Maintenance Practices	
52-20	BATTERY BAY DOOR	52-05

52-00 GENERAL

This chapter describes the ALPHA Electro's doors. The windshield, upper window and door windows are made from Lexan shatter-resistant polycarbonate. The fuselage has two cabin doors made out of CFRP frames and one independent luggage compartment door on the left side. Doors are locked in the closed position via 3 locking pins operated simultaneously by rotating a common central handle.

Each battery bay has a door that provides access to the battery boxes. They can be locked to prevent them from opening during aircraft operation.

52-10
PASSENGER AND CREW
DOORS

52-10 PASSENGER AND CREW DOORS

1. Description

The two crew/passenger doors are fastened to the aircraft by hinges. They incorporate a flush-mounted, outer door handle and a conventional inner door handle. The door latch handle is centered at the bottom of the door window and actuates three latching pins that extend downwards/outwards into the fuselage.

2. Maintenance practices

52-10: 2.1.1. Removal

Step	Action	Required parts, materials and tools	Reference
1	Put the door handle in the locked position.	- 2.5 mm T-handle hex head screwdriver, - rubber hammer	
2	Push the hinge pins out of the door's hinges using the T-handle hex head screwdriver and rubber hammer.		
3	Unlock the door handle and remove the door.		

52-10: 2.1.2. Installation

Step	Action	Required parts, materials and tools	Reference
1	Position door on the airframe and put door handle in locked position	- 2.5 mm T-handle hex head screwdriver, - rubber hammer	
2	Lubricate hinge pin.		12-20
3	Slide hinge pin into hinge and center it.		
4	Unlock door handle and carry out operational check.		05-20

52-10: 2.1.3. Inspection/check

Step	Action	Required parts, materials and tools	Reference
1	Carry out visual inspection of doors.	- 2.5 mm T-handle hex head screwdriver, - rubber hammer	05-20
2	Position door on the airframe and put door handle in locked position.		
3	Use T-handle hex head screwdriver and rubber hammer to remove the doors hinge pins.		
4	Wipe the hinge pins clean with paper towel.		
5	Lubricate hinge pin.		12-20
6	Slide hinge pin into hinge and center it.		
7	Unlock door handle and carry out operational check.		05-20

52-20 BATTERY BAY DOOR

1. Description

The battery bay door provides access to the battery boxes and rests up against a seal to prevent the ingress of water. The fore door is hinged on the upper edge, while the aft is hinged on the side. Both doors can be locked with a key.

PIPISTREL

This page is intentionally left blank.

53

CHAPTER 53 – FUSELAGE

TABLE OF CONTENTS

SECTION	SUBJECT	PAGE NUMBER
53-00	GENERAL	53-03
53-10	MAIN FRAME	53-06
	Description Maintenance Practices	
53-20	CABIN FLOOR	53-07
	Description Maintenance Practices	
53-30	FIREWALL	53-08
	Description Maintenance Practices	

53-00 GENERAL

The ALPHA Electro's fuselage incorporates a carbon fiber construction, reinforced with various bulkheads and longerons. This chapter describes all of the main fuselage elements and the maintenance practices that pertain to them.

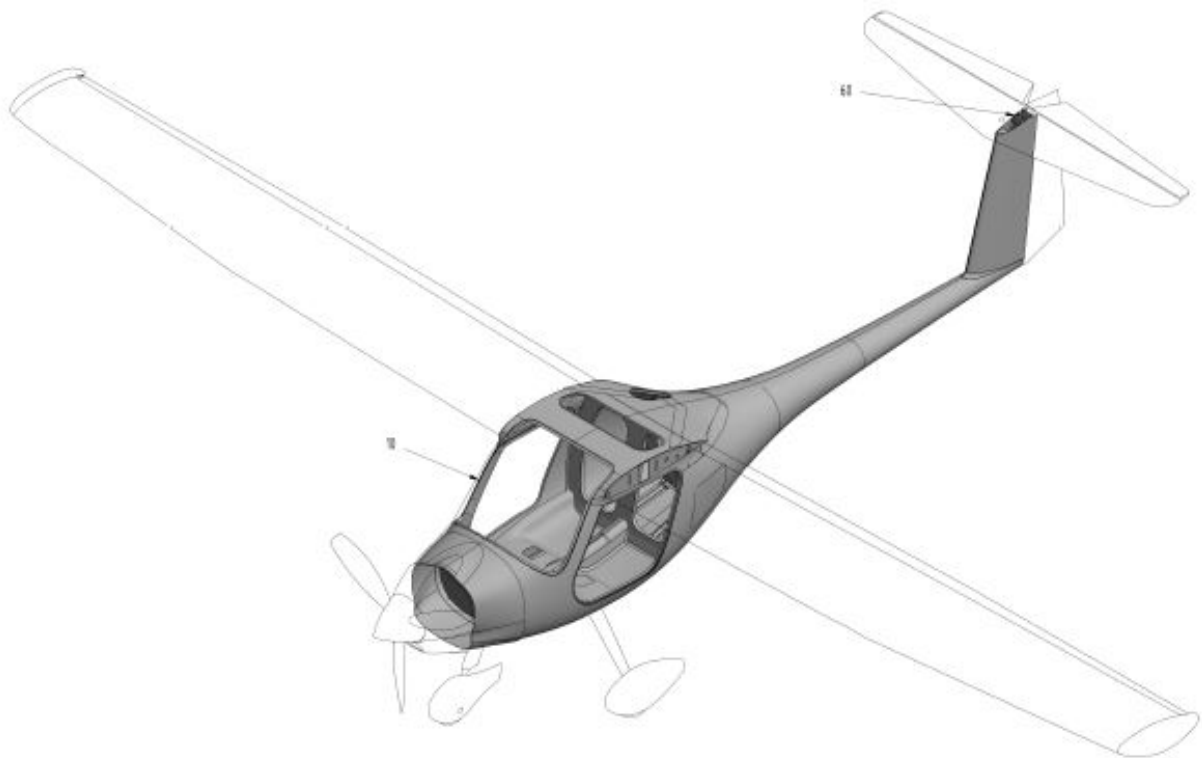

53-10 MAIN FRAME

1. Description

The fuselage is designed as a carbon fiber construction that uses aramid fibers as inner laminate in the cockpit area. The external structure is covered by a protective acrylic paint coating, which has already been applied in the mold.

2. Maintenance practices

53-10: 2.1. Main frame

53-10: 2.1.1. Inspection/check

Step	Action	Required parts, materials and tools	Reference
1	Carry out visual inspection of the fuselage main frame.		51-10
2	Carry out visual inspection of the area where the main landing gear strut is attached to the main frame. Check for any signs of damage, such as cracks, delamination or deformation.		Figure 53-001

WARNING: Any damage incurred by the fuselage's main frame is a safety hazard and must be repaired immediately by an authorized maintenance/composite repair organization.



Figure 53-001
Example of fuselage main frame damage

53-20 CABIN FLOOR

1. Description

The cabin floor supports the crew seats and is made primarily out of CFRP. Some areas of the cabin floor are reinforced with aramid fibers. It's supported by two longerons and a central beam. The passenger safety harness lap belts are fastened to the cabin floor.

2. Maintenance practices

53-20: 2.1.1. Inspection/check + tap test

Step	Action	Required parts, materials and tools	Reference
1	Remove the crew seats.		25-10
2	Carry out visual inspection of the cabin floor. Pay special attention to the area around the safety harnesses attachment points. Check for any signs of damage, such as cracks, delamination or deformation.		05-20 and Figure 53-001
3	Carry out tap test in area adjacent to undercarriage strut bolt attachment points.		51-10
4	Install the crew seats.		25-10

WARNING: Any damage incurred by the fuselage's cabin floor requires immediate repair and must be carried out by an authorized maintenance/composite repair organization.



Figure 53-002
Safety harness attachment point on the cabin floor

53-30 FIREWALL

1. Description

The firewall is designed to separate the motor compartment from the rest of the fuselage and support various airplane components on both the forward and aft side. The firewall, constructed of a CFRP prepreg honeycomb sandwich, includes metal fittings that support the motor mount and reinforced points that support various motor components. Fire protection is provided by a layer of ceramic insulation covered by a sheet of stainless steel.

2. Maintenance practices

53-30: 2.1.1. Inspection/check

Step	Action	Required parts, materials and tools	Reference
1	Remove cowlings.		71-10
2	Carry out visual inspection of the firewall. Check for any signs of deformation due to high temperatures, such as deformation, charring or scorching. Check the area around the motor mount attachment points for signs of damage.		05-20
3	Install the cowlings.		71-10

WARNING: Any damage incurred by the fuselage's firewall requires immediate attention and must be repaired out by an authorized maintenance/composite repair organization.

55

CHAPTER 55 – STABILIZERS

TABLE OF CONTENTS

SECTION	SUBJECT	PAGE NUMBER
55-00	GENERAL	55-03
55-10	HORIZONTAL STABILIZER	55-04
	Description Maintenance Practices	
55-20	ELEVATOR	55-08
	Description Maintenance Practices	
55-30	VERTICAL STABILIZER	55-
	Description Maintenance Practices	
55-40	RUDDER	55-
	Description Maintenance Practices	

55-00 GENERAL

The stabilizers consist of a detachable horizontal stabilizer, a single piece elevator, a fixed vertical stabilizer and a detachable rudder. All of the empennage components are conventional spar (shear web), rib, and skin construction. This chapter describes the maintenance practices that pertain to the aforementioned components.

NOTE: The COG of the aircraft must be recalculated/verified following any stabilizer/control surface repairs.

55-10
HORIZONTAL
STABILIZER

55-10 HORIZONTAL STABILIZER

1. Description

The horizontal stabilizer is attached to an aluminum bracket that is fastened to the vertical stabilizer and can be removed. The design of the horizontal tail's shell incorporates CFRP sandwich material.

2. Maintenance practices

55-10: 2.1. Horizontal stabilizer

55-10: 2.1.1. Removal

Step	Action	Required parts, materials and tools	Reference
1	Weigh the tail cone down to access the horizontal stabilizer.	- 14 mm spark plug socket wrench (P/N 1190003), - flathead screwdriver	07-10: 2.2.1.
2	Remove the attachment bolt's black cap.		
3	Slide screwdriver perpendicularly through 14 mm socket wrench and use it to unscrew/remove the horizontal stabilizers' attachment bolt assembly.		
4	Lightly jolt the elevator's trailing edge, so that the horizontal stabilizer pops out of place.		
5	Remove it and set it on a dry, padded surface.		
6	Remove tail cone counterweight.		

55-10: 2.1.2. Installation

Step	Action	Required parts, materials and tools	Reference
1	Weigh the tail cone down to access the horizontal stabilizer .	- 14 mm spark plug socket wrench (P/N 1190003), - flathead screwdriver	07-10: 2.2.1.
2	Lubricate horizontal stabilizer pins and bushings.		
3	Lubricate horizontal stabilizer attachment bolt assembly		12-20
4	Position the horizontal stabilizer so that it's pins slide into their respective bushings.		
5	Use 14 mm socket wrench to fasten the horizontal stabilizer to the aircraft while simultaneously pushing down on the bolt with the screwdriver.		Figure 55-001
6	Orient the bolt's head so that slides into the spring-loaded locking mechanism.		Figure 55-002
7	Shake stabilizer a little to ensure it is secured to the aircraft.		
8	Install the attachment bolt assembly's black cap.		

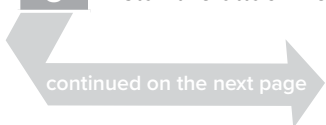

Step	Action	Required parts, materials and tools	Reference
9	Carry out operational inspection of the elevator.		05-20)
10	Check elevator deflection angles.		27-30)

55-10: 2.1.3. Inspection/check

Step	Action	Required parts, materials and tools	Reference
1	Remove horizontal stabilizer.	Retainer ring pliers	55-10: 2.1.
2	Remove attachment bolt retainer ring.		
3	Remove attachment bolt assembly.		
4	Carry out visual inspection of attachment bolt assembly.		05-20
5	Clean and lubricate attachment bolt assembly.		12-20
6	Install attachment bolt assembly.		
7	Carry out operational inspection of attachment bolt assembly.		05-20



Figure 55-001
Attachment bolt installation



Figure 55-002
Attachment bolt assembly head orientation

55-20 ELEVATOR

1. Description

The elevator is designed as a bottom surface supported hinged flap. The elevator is actuated using a pushrod, which is connected to the elevator control bracket. The elevator shell is designed as a 1-cell CFRP sandwich shell. The elevator is hinged in maintenance-free bushings mounted on stainless steel brackets at the stabilizer rear spar and bottom shell. Counterbalance weights are integrated into the elevator tips.

2. Maintenance practices

55-20: 2.1. Elevator

55-20: 2.1.1. Removal

Step	Action	Required parts, materials and tools	Reference
1	Remove horizontal stabilizer.	Metric ratchet/socket set	55-10
2	Flip it upside down on a dry, padded surface.		
3	Remove the fastening material from the first port-side hinge securing the elevator to the horizontal stabilizer.		
4	Slightly wiggle the elevator up and down while simultaneously sliding it off its hinges.		
5	Remove and place on a dry, padded surface.		

55-20: 2.1.2. Installation

Step	Action	Required parts, materials and tools	Reference
1	Slide elevator into position on the horizontal stabilizer and fasten it in place.	Metric ratchet/socket set	
2	Carry out operational inspection of the elevator.		05-20
3	Install horizontal stabilizer.		55-10
4	Check elevator deflection angles.		27-30

55-20: 2.1.3. Inspection/check

Step	Action	Required parts, materials and tools	Reference
1	Remove elevator.	Metric ratchet/socket set	55-10: 2.1.
2	Carry out visual inspection of the elevator.		05-20
3	Lubricate elevator hinge pins.		12-20
4	Install elevator.		55-10: 2.1.2.

55-30 VERTICAL STABILIZER

1. Description

The vertical stabilizer is designed to be one part with the tail fuselage, made of carbon honeycomb sandwich with carbon spars. The bending moment is carried by one C-type spar which is reinforced by CFRP tapes at the flanges.

2. Maintenance practices

55-30: 2.1. Vertical stabilizer

55-30: 2.1.1. Inspection/check

Step	Action	Required parts, materials and tools	Reference
1	Remove horizontal stabilizer.		55-10: 2.1.
2	Carry out visual inspection of vertical stabilizer bushings for wear.		05-20
3	Clean and lubricate vertical stabilizer bushings.		
4	Clean and lubricate horizontal stabilizer T-fixation plate pins.		12-20
5	Install horizontal stabilizer.		55-10: 2.1.2.

55-30: 2.1.2. Inspection/check + tap test

Step	Action	Required parts, materials and tools	Reference
1	Remove horizontal stabilizer.		55-10: 2.1.
2	Carry out tap test around the vertical stabilizer bushings.		51-10
3	Install horizontal stabilizer.		55-10: 2.1.2.

55-40
RUDDER

55-40 RUDDER

1. Description

The rudder is a single-cell GFRP sandwich shell that's designed like centrally supported hinged flap. It's rotation is attributed to two maintenance-free spherical plain bearings. Balancing weights are mounted on the front end of the rudder.

2. Maintenance practices

55-40: 2.1. Rudder

55-40: 2.1.1. Removal

Step	Action	Required parts, materials and tools	Reference
1	Remove the fastening material securing the rudder's two bottom studs to the rudder cable bellcrank.	Metric ratchet/ socket set	
2	Support the rudder with both hands and give it a jolt upwards. It should slide of its hinges.		
3	Place it on a dry, padded surface.		
4	Carry out visual inspection of the rudder.		05-20 and 51-10

55-40: 2.1.2. Installation

Step	Action	Required parts, materials and tools	Reference
1	Lubricate the upper rudder hinge pin.	Metric ratchet/ socket set	12-20
2	Slide the rudder's upper bushing over its upper hinge pin while simultaneously sliding its two bottom studs into the cable bellcrank.		
3	Fasten it in place and torque nuts.		
4	Carry out operational inspection.		05-20
5	Check the rudder deflection angles.		27-20

56

CHAPTER 56 – WINDOWS

TABLE OF CONTENTS

SECTION	SUBJECT	PAGE NUMBER
56-00	WINDOWS General Description Maintenance practices	56-03

56-00 GENERAL

1. Description

The ALPHA Electro is equipped with a windshield, cabin door windows and a sunroof. All of the aforementioned windows are made from Lexan shatter-resistant polycarbonate and bonded/fastened to the fuselage or door structure using adhesive and rivets. All the windows are fixed in place and cannot be opened, the exception being the doors which have sliding windows for direct fresh ram air into the cabin.

2. Maintenance practices

NOTE: The following maintenance practices apply to all of the ALPHA Electro's window surfaces (i.e. windshield, sunroof and door).

56-00: 2.1. Windows

56-00: 2.1.1. Surface inspection/check

Step	Action	Required parts, materials and tools	Reference
1	Carry out visual inspection of the window.		51-10
	Inspect the window for any signs of damage such as cracks, scratches, chips or smudges.		Figure 56-001
	Inspect the windows clarity: objects should appear clear and hazy or fuzzy.		Figure 56-002 and Figure 56-003



Figure 56-001
Cracked windshield

56-00
GENERAL



Figure 56-002
Example of adequate window clarity

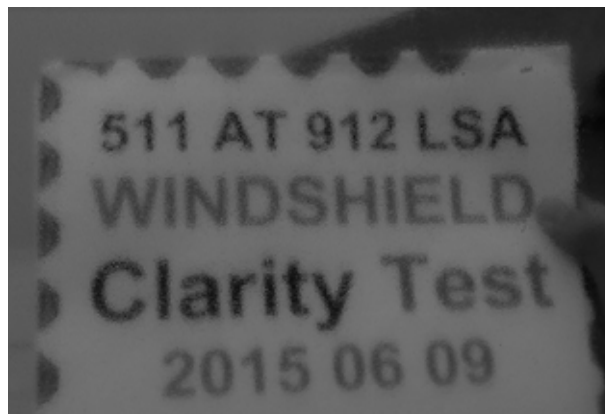

Figure 56-003
Example of inadequate window clarity

WARNING: Damaged windows that impede pilot visibility are a safety hazard and must be replaced.

56-00: 2.1.2. Rivet inspection/check

Step	Action	Required parts, materials and tools	Reference
1	Carry out visual inspection of the window rivets. Make sure that none of them have loosened and/or gone missing. They should all be flush with the window's surface.		05-20 Figure 56-004



Figure 56-004
Example of loosened window rivet

CAUTION: Any damaged and/or loosened window rivets must be replaced with new ones.

PIPISTREL

This page is intentionally left blank.

57

CHAPTER 57 – WINGS

TABLE OF CONTENTS

SECTION	SUBJECT	PAGE NUMBER
57-00	GENERAL	57-03
57-10	WING STRUCTURE	57-04
	Description Maintenance Practices	
57-40	ATTACH FITTINGS	57-07
	Description	
57-50	FLIGHT SURFACES	57-08
	Description Maintenance Practices	

57-00 GENERAL

The detachable wing is a single spar cantilever wing. The left and right wing are connected by two pins through the spar ends. The wing structure is made mostly from CFRP, while the main spar shear web and the root ribs are made from GFRP. This is for visual inspection and easier damage detection reasons. The spar caps are produced using carbon roving. The wing spar is designed as double T-type spar. Lateral loads and twisting moments are conventionally transferred to the fuselage through root ribs and lateral-force bolts.

57-10
WING STRUCTURE

57-10 WING STRUCTURE

1. Description

The wing shell is designed as a 2-cell CFRP sandwich shell which is closed by a rear shear web which the flaperons are attached to. The wings are fastened together the same way classic gliders are - two spar ends connected with two spar pins. There is also a middle bolt which mates the wings to the fuselage and provides torsional stiffness. The wing roots have pins that slide into bushings in the fuselage and thus allow the wings to be easily positioned/fitted.

2. Maintenance practices

CAUTION: Installing and removing the ALPHA Electro’s wings must be carried out in a space where the temperature is equal to or lower than 20°C, as temperature higher than this could make certain parts very difficult to assemble.

57-10: 2.1. Wing structure

57-10: 2.1.1. Wing removal

NOTE: A minimum of three people are required to carry out this task.

Step	Action	Required parts, materials and tools	Reference
1	Engage the parking brake.	Metric ratchet and socket set, T-handle hex head screwdriver set	
2	Place wheel chocks under main landing gear wheels.		
3	Remove white wing-fuselage joint seal.		
4	Remove pitot tube.		34-10
5	Enter the cabin and disconnect static/pitot lines and electrical cables from the wing roots.		
6	Support each wing at the wingtip.		Figure 57-001
7	Remove central wing spar bolt.		
8	With both wings supported at their ends, remove the two spar pins.		
<p>NOTE: Moving the wingtips up and down slightly makes spar pin removal easier.</p>			
9	With one person at each end of the wing, slowly remove one of the wings from the fuselage.		
10	Place it in wing cart or on any dry, padded surface.		

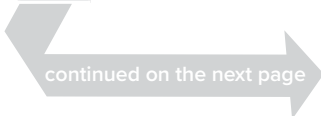

Step	Action	Required parts, materials and tools	Reference
11	With one person at each end of the wing, slowly remove the other wing from the fuselage.		
12	Place it in wing cart or on any dry, padded surface.		
13	Disengage parking brake.		
14	Remove wheel chocks.		
15	Carry out visual inspection of the wings.		

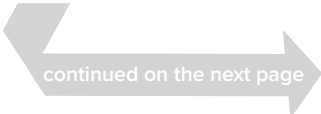

Figure 57-001
Support the wings

57-10: 2.1.2. Wing installation

NOTE: A minimum of three people are required to carry out this task.

Step	Action	Required parts, materials and tools	Reference
1	Clean spar pins, wing positioning pins/bushings and wing spar bushings with a piece of paper towel and lubricate them.	- metric ratchet and socket set, - T-handle hex head screwdriver set, - paper towel, white wing-fuselage joint seal (P/N 5230014)	12-20
2	Engage the parking brake.		
3	Place wheel chocks under main landing gear wheels.		
4	Support one wing at both ends and slide its spar into the fuselage. When the wing root is about 10 cm away from the fuselage all/any electrical cables through their respective openings in the fuselage. Slide the wing into its final position using the wing positioning pins as a guide. Continue to support the wingtip as the spar rests against the fuselage.		



57-10
WING STRUCTURE

Step	Action	Required parts, materials and tools	Reference
5	Support the other wing at both ends and slide its spar into the fuselage. When the wing root is about 10 cm away from the fuselage put all/any electrical cables through their respective openings in the fuselage. Slide the wing into its final position using the wing positioning pins as a guide. Continue to support the wingtip as the spar rests against the fuselage.		
	CAUTION: While pushing the wings into their final position make sure that the flaperon controls have engaged properly.		
6	With the wings supported at their wingtips, slide the spar pins through the wing spar bushings and fasten them in place.		
	CAUTION: If at this point the spar pins are properly inserted and the wings are secured, it is no longer necessary to support the wingtips.		
7	Install central spar bolt and fasten it in place.		
8	Carry out operational check of the flaperon control system.		05-20
9	Connect all electrical cables and pitot/static lines.		
	CAUTION: The pitot and static lines are marked in the cabin and on the lines themselves with a P and S respectively.		
10	Install pitot tube.		
11	Carry out operational check of the pitot tube.		05-20
12	Apply white wing-fuselage joint seal.		

57-10: 2.1.3. Major inspection

NOTE: A minimum of three people are required to carry out this task.

Step	Action	Required parts, materials and tools	Reference
1	Remove the wings.		57-10: 2.1.
2	Remove flaperons.		57-10: 2.1.
3	Remove wing access panel.		
4	Use borescope to carry out visual inspection of wing's internal structure and electrical installations. Lubricate rod end bearings.		Table 12-002
5	Install flaperons.		57-50: 2.1.3.

57-40 ATTACH FITTINGS

1. Description

The ALPHA Electro's wings mate to the fuselage using two pins in the wing root that slide into bushings bonded into the fuselage. Once mated to the fuselage the wings are then fastened together using two spar pins and again to the cabin support strut assembly using an M10 bolt.

57-50
FLIGHT
SURFACES

57-50 FLIGHT SURFACES

1. Description

Roll on the ALPHA Electro is controlled using flaperons that are activated using pushrod mechanisms. A flap handle can be found in the cabin that allows the pilot to symmetrically displace the flaperons. This chapter describes the maintenance practices that apply to the apply to the flaperons.

2. Maintenance practices

57-50: 2.1. Flight surfaces

57-50: 2.1.1. Removal

Step	Action	Required parts, materials and tools	Reference
1	Remove the wings.	Metric combination wrench set	57-10
2	Place the wing upside down on a dry, padded surface.		
3	Locate the flange hinge opening closest to the wing root, remove cotter pin and castellated nut securing the flaperon to the wing.		
4	Slide the flaperon off its hinges by pushing it towards the wing root.		
5	Carry out visual inspection of the flaperon.		05-20

57-50: 2.1.2. Inspection/check

Step	Action	Required parts, materials and tools	Reference
1	Remove the flaperon.	Paper towel, Phillips screwdriver	57-50
2	Check flaperon and its hing pins for any signs of damage, wear or corrosion.		
3	Clean hinge bushings and hinge pins with a paper towel.		
4	Check that the hinge pins have not come loose by sliding a screwdriver through them and applying a bit of torque.		
5	Lubricate the hinge bushings and pins.		12-20

57-50: 2.1.3. Installation

Step	Action	Required parts, materials and tools	Reference
1	Fit the flaperon to the wing by sliding its hing pins into the hinge bushings on the wing.	Metric combination wrench set, Loctite 243	
2	Install castellated nut and cotter pin.		
3	Carry out operational check of the flaperon.		05-20

CAUTION: After being installed the flaperon must move completely unhindered. If this is not the case the castellated nut may have been tightened too much. If this is the case, unscrew the castellated nut a little, reinstall the cotter pin and carry out the operational check again.

PIPISTREL

This page is intentionally left blank.

61

CHAPTER 61 – PROPELLER

TABLE OF CONTENTS

SECTION	SUBJECT	PAGE NUMBER
61-00	GENERAL	61-03
61-10	PROPELLER ASSEMBLY Description Maintenance Practices	61-04

61-00 GENERAL

The ALPHA Electro is equipped with a 3-blade, fixed-pitch propeller all composite propeller FP03-60E. This chapter describes the propeller assembly in detail and discusses the maintenance practices involved.

61-10
PROPELLER
ASSEMBLY

61-10 PROPELLER ASSEMBLY

1. Description

The ALPHA Electro propeller assembly consists of an aluminum hub, spinner, backplate, all-composite propeller and fastening material.

Propeller Technical Specifications	
Designation	FP03-60E
Number of blades	3
Diameter	1640 mm (")
Max safe prop rpm *	2575 rpm
Spinner Diameter	350 mm (1.15")
Fastening bolt torque	24 Nm

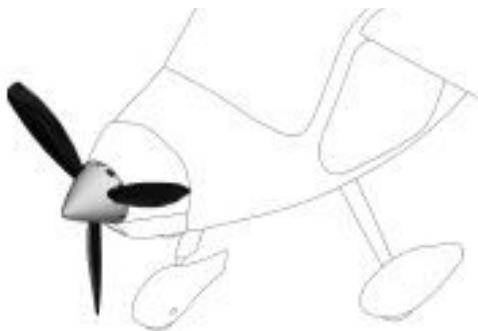

Figure 61-001
FP03-60E Propeller

2. Maintenance practices

CAUTION: Prior to servicing the propeller the area around the aircraft must be cleared and bar-ricade tape put up, to warn passers by of the possible hazard.

WARNING: Turn the MASTER, AVIONICS, BAT EN and PWR EN switches off and disconnect the battery boxes prior to conducting any work on the propeller assembly.

Please refer to [4] for information about the maintenance and servicing procedures that apply to ALPHA Electro's propeller.

PIPISTREL

This page is intentionally left blank.

71

CHAPTER 71 – POWER PLANT

TABLE OF CONTENTS

SECTION	SUBJECT	PAGE NUMBER
71-00	POWER PLANT	71-03
	Description Maintenance practices	
71-10	COWLINGS	71-07
	Description Maintenance Practices	
71-20	MOUNTS	71-08
	Description Maintenance Practices	
71-50	ELECTRICAL HARNESSSES	71-09
	Description Maintenance Practices	

71-00 POWER PLANT

1. Description

This chapter covers all the maintenance practices involved with the following components: power controller, baffling, cowling, mount, attach fittings, electrical harnesses and drains.

2. Maintenance Practices

71-00: 2.1. Baffling

71-00: 3.1.1. Removal

Reference: Figure 72-001

Step	Action	Required parts, materials and tools	Reference
1	Remove cowlings.	- Silicone remover (Non-aggressive and solvent-based), - box cutter	71-10:2.1.1.
2	Tear seal away by hand. Use box cutter if necessary, being careful not to damage the component the seal bonded to.		
3	Apply some silicone remover to any residual silicone that is difficult to remove.		

71-00: 3.1.2. Installation

Reference: Figure 72-001

Step	Action	Required parts, materials and tools	Reference
1	Clean the surface with pure acetone and wait for the surface to dry.	- Silicone (neutral, permanently elastic, one-component, permanent exposure 250°C, temporary exposure 300°C), - Primer (3m 4297), - Acetone (pure)	71-10:2.1.2
2	Apply primer.		
3	Remove protective foil from back of foam.		
4	Apply foam.		
5	Seal gap between foam and component using silicone.		
6	Install cowlings.		



Figure 71-001
Baffling between lower cowling and cooler

71-00: 2.2. Power controller

71-00: 2.2.1. Removal

Step	Action	Required parts, materials and tools	Reference
1	Remove cowlings.		71-10: 2.1.1.
2	Remove aft and fore battery box.		24-30: 2.1.1.
3	Fasten the motor to motor stand.		
4	Remove fastening material securing motor mount to firewall.		
5	Move stand slightly away from firewall.		
6	Cut any zip ties securing cables to the motor mount.		
7	Remove expansion tank.		75-20: 2.3.1.
8	Locate harness between junction box and instrument panel. Unplug connector from junction box. .		
9	Drain cooling system.		12-20: 2.3.
10	Loosen and remove cooling system banjo fittings on top of power controller.		
11	Release or cut hoses between power controller and motor ,and between power controller and water pump.		

CAUTION: Hoses disconnected from fittings must be replaced by new ones.

12	Remove screws securing power controller cover to power controller. Remove cover.		
13	Remove fastening material securing all power cables from junction box and motor.		
14	Loosen grommet nuts securing cables to power controller housing and remove all power cables.		
15	Remove fastening material securing power controller to firewall.		
16	Remove power controller.		



Figure 71-002
Power controller connections

71-00: 2.2.2. Installation

Step	Action	Required parts, materials and tools	Reference
1	Remove cowlings.		71-10: 2.1.1.
2	Remove aft and fore battery box.		24-30: 2.1.1.
3	Put bolts through holes in firewall from inside of fore battery bay.		
4	Apply Loctite 243 to nuts.		
5	Place spacers between power controller and firewall.		
6	Fasten power controller to firewall. Place grounding cable under bottom port nut.		
7	Remove screws securing power controller cover to power controller.		
8	Remove power controller cover.		
9	Insert blue motor power cable into hole on top of power controller.		
10	Continue with red and black motor power cables installation into respective holes.		

Figure 71-002



Figure 71-003
Power controller terminals

11	Secure cables to power controller housing by tightening grommet nuts.		
12	Fasten cables lugs to respective terminals.		Figure 71-003
13	Torque to 5 Nm.		
14	Insert power cables from junction box. Red cable through starboard hole and blue through port hole.		
15	Fasten cables lugs to respective terminals.		Figure 71-003
16	Secure cables to power controller housing by tightening grommet nuts.		

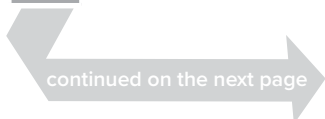

71-00
POWER PLANT

Step	Action	Required parts, materials and tools	Reference
17	Connect both electrical harnesses to power controller.		
18	Secure cables with zip ties.		
19	Fasten power controller cover to power controller.		
20	Install hose between power controller cooling outlet (starboard banjo) and motor cooling inlet.		
21	Install hose between pump outlet and power controller cooling inlet (port banjo).		
22	Apply Loctite 577 to banjo fitting thread and install fittings into power controller.		
23	Install junction box.		24-60: 2.1.2.
24	Install expansion tank.		75-20: 2.3.2.
25	Install aft and fore battery box.		24-30: 2.1.2.
26	Install cowlings.		71-10: 2.1.2.

71-00: 2.2.3. Inspection/check

Step	Action	Required parts, materials and tools	Reference
1	Remove cowlings.		71-10: 2.1.1.
2	Remove aft and fore battery box.		24-30: 2.1.1.
3	Remove screws securing power controller cover to power controller and remove cover.		
4	Check power cable fastening material. Torque if necessary. (5 Nm)		
5	Fasten power controller cover to power controller.		
6	Install aft and fore battery box.		24-30: 2.1.2.
7	Install cowlings.		71-10: 2.1.2.

71-10 COWLINGS

1. Description

The ALPHA Electro comes equipped with two tight-fitting, all-composite cowlings that protect the power plant components and ensure superb cooling. They're attached to the fuselage and to each other by screws that allow the user to install and remove them easily.

2. Maintenance Practices

71-10: 2.1. Cowlings

71-10: 2.1.1. Removal

NOTE: Installing and removing the cowlings, although it can be done by one person alone, is much easier to carry out with the help of someone else. This will also decrease the chances of any components getting scratched or damaged.

Step	Action	Required parts, materials and tools	Reference
1	Remove screws securing upper cowling to lower cowling and fuselage.		
2	Remove upper cowling from airplane.		
3	Remove all screws securing lower cowling to the fuselage.		
4	Slowly move lower cowling downwards and remove.		

71-10: 2.1.2. Installation

Step	Action	Required parts, materials and tools	Reference
1	Position bottom cowling.		
2	Fasten it to fuselage using screws.		
3	Position upper cowling.		
4	Fasten it to fuselage and lower cowling using screws.		

**71-20
MOUNTS**

71-20 MOUNTS

1. Description

The ALPHA Electro’s power plant is attached to the airframe by several tubular steel weldments, one of which incorporates three conventional elastomeric isolators for vibration damping. The mount is bolted to the composite firewall in three locations. The firewall attachment points are structurally reinforced with gusset-type attachments that transfer thrust and bending loads into the fuselage shell. There is an aluminum flange that rests between the motor itself and mount

2. Maintenance Practices

71-20: 2.1. Motor mount

71-20: 2.1.1. Inspection/check

Step	Action	Required parts, materials and tools	Reference
1	Remove cowlings.	- Torque wrench	71-10: 2.1.1.
2	Inspect entire mount for any signs of wear, such as cracks and/or deformation. Particular attention needs to be paid to the mount’s joints, where two tubes meet and are welded together.		
3	Inspect fastening material paint marker. Check if any bolts have loosened. Verify torque using torque wrench.		20-30
4	Install cowlings.		71-10: 2.1.2.

71-20: 2.2. Vibration damping isolators

71-20: 2.2.1. Inspection/check

Step	Action	Required parts, materials and tools	Reference
1	Remove cowlings.		71-10: 2.1.1.
2	Inspect isolators for any signs of wear, such as cracks, deformation, tears, etc. Replace if necessary.		
3	Install cowlings.		71-10: 2.1.2.

71-50 ELECTRICAL HARNESSES

1. Description

The ALPHA Electro's power plant incorporates various power cables, data/communication cables and electrical harnesses. Please refer to chapter 91 for the wiring diagrams pertaining to them.

PIPISTREL

This page is intentionally left blank.

72

CHAPTER 72 – ELECTRIC MOTOR

TABLE OF CONTENTS

SECTION	SUBJECT	PAGE NUMBER
72-00	ELECTRIC MOTOR Description Maintenance Practices	75-03

72-00 ELECTRIC MOTOR

1. Description

The ALPHA Electro is equipped with a synchronous 3-phase, liquid-cooled motor with permanent magnets. It's rated at 60kW and weighs 20kg.

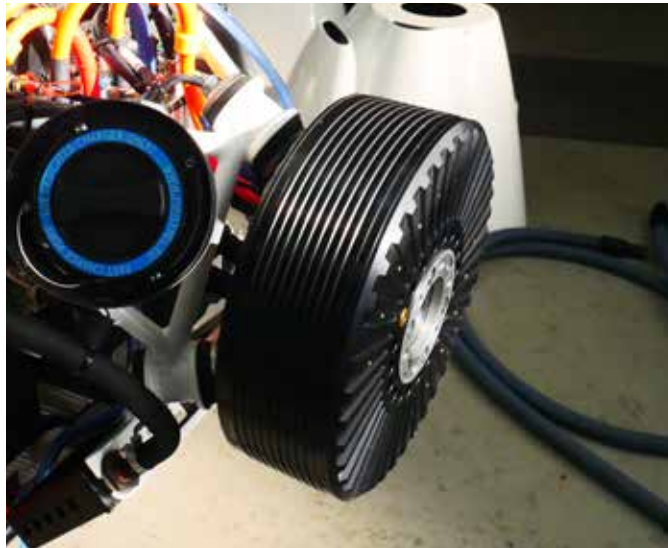

Figure 72-001
Electric motor

2. Maintenance Practices

71-20: 2.1. Electric motor

71-20: 2.1.1. Removal

Step	Action	Required parts, materials and tools	Reference
1	Remove cowlings.		71-10: 2.1.1.
2	Remove aft and fore battery box.		24-30: 2.1.1.
3	Drain cooling system.		12-20: 2.3.
4	Fasten motor to motor stand.		
5	Perform junction box removal procedure up to step 10.		24-60: 2.1.1.

continued on the next page

Step	Action	Required parts, materials and tools	Reference
6	Cut/remove hoses leading into pump.		
7	Disconnect expansion tank silicone tube.		
8	Remove screws securing expansion tank to firewall.		
9	Remove bolts securing motor mount to firewall.		
10	Remove fastening material securing power controller to firewall from fore battery bay.		
11	Disassembly FCP by removing screws on backside of housing.		
12	Disconnect wires leading between FCP and instrumental panel according to wiring diagram.		91-00
13	Remove mount and accompanying assemblies by moving motor stand away from aircraft.		
14	Support mount and accompanying assemblies before removing motor stand.		
15	Perform steps 10 to 13 of <i>power controller removal procedure</i> .		71-00: 2.2.1.
16	Remove the power controller.		
17	Remove bolts securing motor to motor mount.		
18	Remove motor.		
19	Install aft and fore battery box.		24-30: 2.1.2.
20	Install cowlings.		71-10: 2.1.2.



Figure 72-002
Sliding motor mount

71-20: 2.1.1. Installation

Step	Action	Required parts, materials and tools	Reference
1	Remove cowlings.		71-10: 2.1.1.
2	Remove aft and fore battery box.		24-30: 2.1.1.
3	Apply grease to barbed brass fitting thread and fit with o-ring.		
4	Fit barbed brass fitting with o-ring.		
5	Wipe away grease with paper towel.		
6	Apply Loctite 577 to fitting thread and install in motor cooling inlet.		
7	Locate second barbed brass fitting. Repeat steps 3-5.		
8	Locate motor mount with flange already fastened to it. Fit flange with second brass barbed fitting and apply Loctite 577 to fitting thread.		
9	Slide motor mount/flange over previously-installed barbed brass fitting and position on motor.		Figure 72-002
10	Locate six M8 × 30 head cap bolts and apply Loctite 243 to three.		
11	Fasten motor mount/flange to motor using three screws. Torque to 24 Nm.		
12	Screw barbed brass fittings into motor until they bottom out.		
13	Install last three M8 × 30 head cap bolts. Apply Loctite 243 first. Please grounding wire under bolt beside barbed brass fitting.		
14	Locate two M4 × 20 screws from kit s/n 170600490.		
15	Apply Loctite 243 to screws and fasten rotary sensor (Encoder RLS RM44) to motor flange.		
16	Fasten sensor cable to base of motor mount with zip tie.		
17	Apply grease to barbed brass fittings on motor.		12-10
18	Attach hose (hose length = 50 cm) to barbed brass fitting on motor (cooling outlet)..		
19	Locate banjo fitting and apply Loctite 577 to thread.		
20	Fit with copper seal washer and fasten to power controller cooling inlet on port side.		
21	Repeat steps 19-20 with other banjo fitting power controller cooling outlet on starboard side.		
22	Apply grease to banjo fittings.		12-10
23	Install hose between barbed brass fitting on motor (cooling inlet) and power controller banjo fitting on starboard side (hose length = 31 cm).		
24	Attach hose (hose length = 34.5 cm) to banjo fitting on port side of power controller.		
25	Apply grease to barbed fitting on starboard side of cooler and expansion tank outlet.		12-10

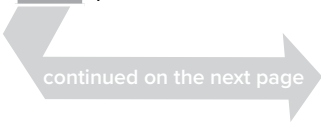

Step	Action	Required parts, materials and tools	Reference
26	Install hose between expansion tank outlet and cooler starboard barbed fitting (hose length = 47 cm).		
27	Apply grease to expansion tank inlet.		
28	Attach hose from step 18 to expansion tank inlet.		
29	Secure hose connections with hose clamps.		
30	Fasten entire assembly to motor stand.		
31	Connect harness connectors between power controller and instrumental panel and between junction box and power controller.		Figure 72-003
32	Fit firewall with power controller fastening bolts from inside of fore battery bay.		



Figure 72-003
Power controller connectors

- 33 Apply Loctite 243 to nuts.
- 34 Fit bolts with spacers.
- 35 Position the power controller on firewall.
- 36 Fasten power controller to firewall at two points first: top port and bottom starboard attachment points.
- 37 Install grounding cables under bottom port nut and tighten.
- 38 Position motor mount on firewall.
- 39 Fasten motor mount to firewall.
- 40 Fasten expansion tank to firewall.
- 41 Apply grease to water pump inlet and outlet.
- 42 Attach hose from step 24 to water pump outlet.

Figure 72-004

continued on the next page

Step	Action	Required parts, materials and tools	Reference
43	Install hose (hose length = 23 cm) between cooler and water pump inlet.		
44	Secure hose connections with hose clamps.		
45	Perform steps from 2 to 16 from <i>junction box installation</i> .		24-60: 2.1.2.
46	Remove motor stand.		
47	Ensure all electrical connections previously disconnected during removal are reconnected.		
48	Install aft and fore battery box.		24-30: 2.1.2.
49	Install cowlings.		71-10: 2.1.2.



Figure 72-004
Grounding cables on power controller

PIPISTREL

This page is intentionally left blank.

75

CHAPTER 75 – POWER PLANT COOLING

TABLE OF CONTENTS

SECTION	SUBJECT	PAGE NUMBER
75-00	GENERAL	75-03
75-20	LIQUID COOLING Description Maintenance Practices	75-04

75-00 GENERAL

The ALPHA Electro's motor and power controller integrated into a cooling circuit, which includes a pump, expansion tank, overflow bottle and cooler. This chapter describes the cooling system the maintenance practices that pertain to it.

75-20 LIQUID COOLING

1. Description

Figure 75-001 shows the cooling system components installed on the ALPHA Electro.

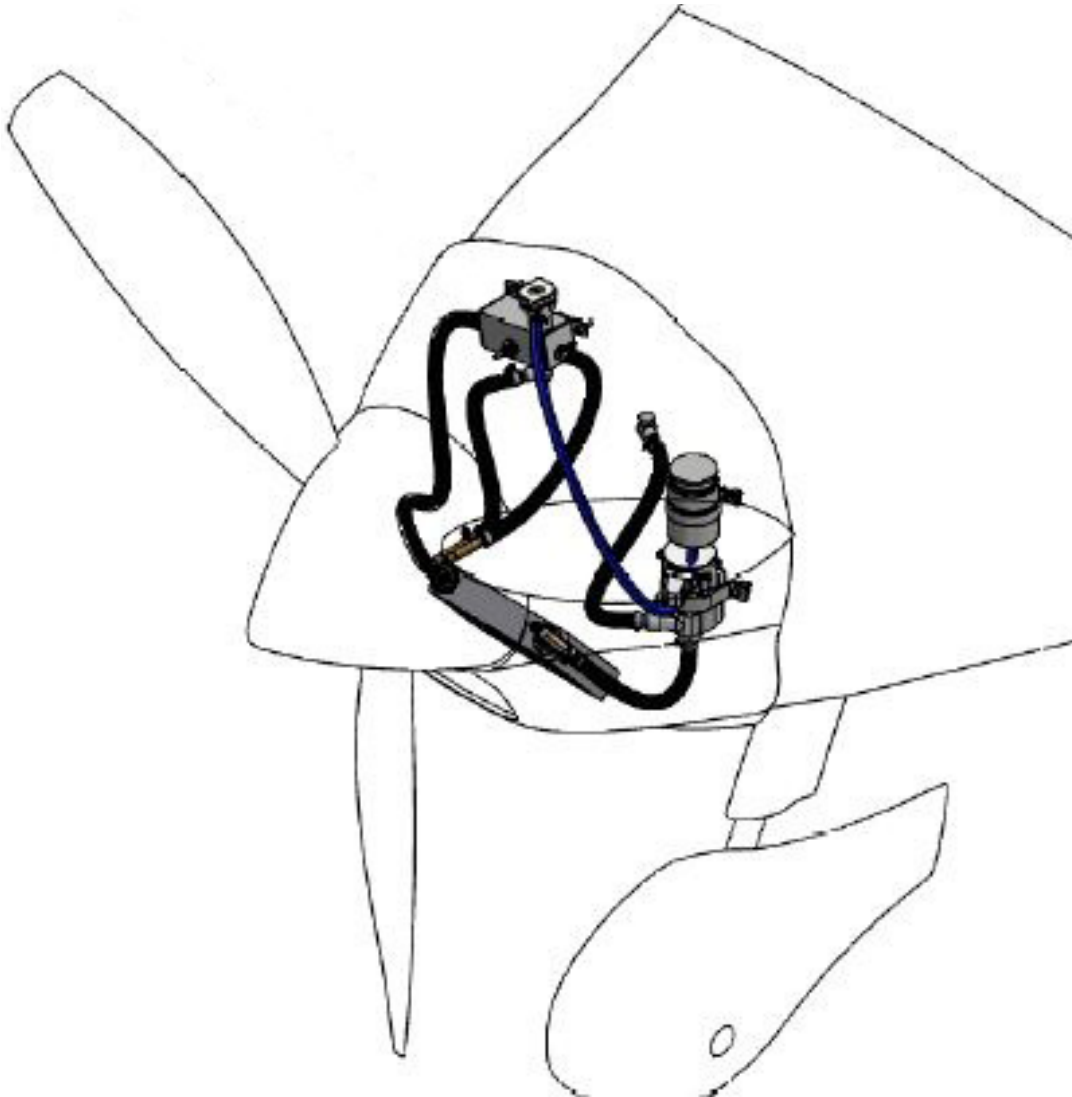

Figure 75-001
Power plant cooling system

2. Maintenance Practices

75-20: 2.1. Pump

75-20: 2.1.1. Removal

Step	Action	Required parts, materials and tools	Reference
1	Remove cowlings.		71-10: 2.1.1.
2	Remove aft and fore battery box.		24-30: 2.1.1.
4	Drain the cooling system.		12-20: 2.3.
5	Disconnect power supply cable from pump.		
6	Remove fastening material securing pump brace to firewall.		
7	Remove water pump.		
8	Install aft and fore battery box.		24-30: 2.1.2.
9	Install cowlings.		71-10: 2.1.2.

71-20: 2.1.1. Installation

Step	Action	Required parts, materials and tools	Reference
1	Remove cowlings.		71-10: 2.1.1.
2	Remove fore and aft battery boxes.		24-30: 2.1.1.
NOTE: Water pump installation requires temporarily removing the overflow bottle so that the water pump spacer can be installed properly.			75-20: 2.4.1.
3	Locate replacement water pump.		
4	Slide both bolts through firewall holes from inside of fore battery bay.		
5	Insert water pump spacer between the pump and firewall.		
6	Apply Loctite 243 to nuts and use them to fasten pump/brace/spacer to firewall.		
7	Reinstall overflow bottle.		75-20: 2.4.2.
8	Apply grease to pump barbed fittings.		
9	Install replacement hoses between water pump and power controller and between water pump and cooler.		
10	Secure hose connections with hose clamps.		
11	Connect power supply cable to the pump.		
12	Replenish cooling system.		12-10: 2.1.

75-20
LIQUID COOLING

75-20: 2.2. Cooler

75-20: 2.2.1. Removal

Step	Action	Required parts, materials and tools	Reference
1	Remove cowlings.		71-10: 2.1.1.
2	Remove aft and fore battery box.		24-30: 2.1.1.
3	Drain cooling system.		12-20: 2.3.
4	Remove water temperature sensor from 180° elbow fitting on port side of cooler.		
5	Release hose clamps securing hoses to cooler.		
6	Disconnect or cut hoses attached to cooler.		

CAUTION: Hoses disconnected from fittings must be replaced by new ones.

7	Loosen nut securing cooler to port side of mount.		
8	Loosen and remove barbed fitting, nut and washers securing cooler to starboard side of mount.		
9	Remove cooler.		
10	Install aft and fore battery box.		24-30: 2.1.2.
11	Install cowlings.		71-10: 2.1.2.

75-20: 2.1.1. Installation

Step	Action	Required parts, materials and tools	Reference
1	Remove cowlings.		71-10: 2.1.1.
2	Remove aft and fore battery box.		24-30: 2.1.1.
3	Apply Loctite 577 to 180° elbow fitting thread.		
4	Fit 180° elbow fitting hex nut and copper seal washer.		
5	Screw 180 elbow fitting into cooler, leave it at 45° angle to cooler and tighten nut with wrench.		Figure 75-002
6	Apply Loctite 577 to other 180° elbow fitting thread.		
7	Fit other end of 180° elbow fitting with copper seal washer and barbed fitting, and tighten with wrench.		
8	Position cooler on motor mount.		
9	Fit the starboard cooler outlet with washer, nut and the copper seal washer.		
10	Tighten nuts securing cooler to mount.		

continued on the next page

Step	Action	Required parts, materials and tools	Reference
11	Apply Loctite 577 to barbed fitting and install hand-tight to starboard cooler outlet.		
12	Tighten starboard barbed fitting with wrench.		
13	Locate replacement hoses.		
14	Apply grease to barbed fittings and 180° elbow fitting.		12-10
15	Install hose between expansion tank outlet and cooler outlet barbed fitting on starboard side.		
16	Install hose between water pump and cooler outlet (180° elbow fitting) on port side.		
17	Secure hose connections with hose clamps.		
18	Apply paint marker to the hose clamp screws and to cooler nuts.		
19	Fit 180° elbow fitting on port side of mount with water temperature sensor.		
20	Replenish cooling system.		12-10: 2.1.
21	Install aft and fore battery box.		24-30: 2.1.2.
22	Install cowlings.		71-10: 2.1.2.



Figure 75-002
Correct cooler outlet positioning

75-20: 2.3. Expansion tank

75-20: 2.3.1. Removal

Step	Action	Required parts, materials and tools	Reference
1	Remove cowlings.		71-10: 2.1.1.
2	Remove aft and fore battery box.		24-30: 2.1.1.
3	Drain cooling system.		12-20: 2.3.
4	Locate, unscrew and remove water temperature sensor.		
5	Cut tie securing blue silicon hose to expansion tank fitting.		
6	Remove blue silicon hose.		
7	Drain any residual fluid from blue silicon hose.		
8	Remove bolts/nuts securing expansion tank to firewall.		
9	Release hose clamps securing hoses to expansion tank.		
10	Remove or cut hoses attached to expansion tank.		
CAUTION: Hoses removed from barbed fittings must be replaced by new ones.			
11	Remove expansion tank.		
12	Install aft and fore battery box.		24-30: 2.1.2.
13	Install cowlings.		71-10: 2.1.2.

75-20: 2.3.2. Installation

Step	Action	Required parts, materials and tools	Reference
1	Remove cowlings.		71-10: 2.1.1.
2	Remove aft and fore battery box.		24-30: 2.1.1.
3	Locate replacement expansion tank and hoses.		
4	Apply grease to expansion tank barbed fittings.		12-10
5	Install hose between expansion tank and cooler.		
6	Install hose between expansion tank and motor.		
7	Secure hoses with hose clamps and mark hose clamp screws with paint marker.		
8	Place expansion tank on firewall.		
9	Apply Loctite 243 to bolts and fasten expansion tank to firewall.		
10	Mark bolt heads with paint marker.		
11	Connect blue silicon hose to expansion tank and secure with tie.		

continued on the next page

Step	Action	Required parts, materials and tools	Reference
12	Apply Loctite 577 to water temperature sensor screw.		
13	Install water temperature sensor.		
14	Replenish cooling system.		12-10: 2.1.
15	Install aft and fore battery box.		24-30: 2.1.2.
16	Install cowlings.		71-10: 2.1.2.

75-20: 2.4. Overflow bottle

75-20: 2.4.1. Removal

Step	Action	Required parts, materials and tools	Reference
1	Remove cowlings.		71-10: 2.1.1.
2	Remove aft and fore battery box.		24-30: 2.1.1.
3	Locate the overflow bottle attached to the firewall on port side of aircraft.		
4	Unscrew nuts securing overflow bottle brace to firewall.		
5	Cut zip tie securing blue silicon hose to the expansion tank.		
6	Remove blue silicon hose.		
7	Remove overflow bottle.		75-20: 2.4.1.
8	Install aft and fore battery box.		24-30: 2.1.2.
9	Install cowlings.		71-10: 2.1.2.

75-20: 2.4.2. Installation

Step	Action	Required parts, materials and tools	Reference
1	Remove cowlings.		71-10: 2.1.1.
2	Remove aft and fore battery box.		24-30: 2.1.1.
3	Apply grease to overflow bottle barbed fitting.		12-10
4	Connect blue silicon hose to overflow bottle fitting and secure it with tie.		
5	Apply Loctite 243 to the nuts and use them to fasten overflow bottle/brace to the firewall.		75-20: 2.4.2.
6	Apply grease to expansion tank fitting and connect blue silicon hose.		12-10
7	Secure blue silicon hose with tie.		
8	Replenish cooling system.		12-10: 2.1.
9	Install aft and fore battery box.		24-30: 2.1.2.
10	Install cowlings.		71-10: 2.1.2.

PIPISTREL

This page is intentionally left blank.

76

CHAPTER 76 – MOTOR CONTROLS

TABLE OF CONTENTS

SECTION	SUBJECT	PAGE NUMBER
76-00	GENERAL Description Maintenance Practices	76-03

76-00 GENERAL

1. Description

This chapter describes the ALPHA Electro's motor control assembly, the system that the pilot uses to operate the motor. It's design is very simple and requires very little maintenance, as it only incorporates a single-lever power (throttle) control lever in a standard control quadrant with a contactless position sensor. The lever is easily accessible to both pilots, as it's fastened to the cabin floor between the two crew seats (see Figure 76-001).



Figure 76-001
Motor control quadrant

76-00
GENERAL

2. Maintenance practices

76-00: 2.1. Motor control quadrant

WARNING: Before performing any maintenance on electrical installations make sure the aircraft's main switches (MASTER, AVIONICS, BAT EN, PWR EN) are OFF and the batteries boxes are disconnected!

76-00: 2.1.1. Inspection/check

Reference:

Step	Action	Required parts, materials and tools	Reference
1	Remove screw securing quadrant cover to seat pan.	- Torx screwdriver set - T-handle hex head screwdriver set	05-20 Figure 76-002
2	Remove quadrant cover.		
3	Perform visual inspection of throttle assembly.		
4	Locate four bolts securing components to brace. (two are highlighted in Figure 76-002)		
5	Check bolt tightness. Tighten if necessary.		
6	Reinstall quadrant cover.		



Figure 76-002
Throttle fastening material

91

CHAPTER 91 – WIRING DIAGRAMS

TABLE OF CONTENTS

FIGURE	SUBJECT	PAGE
	WIRING DIAGRAMS	
	General	3
Figure 167-24-60-000_A00	HV junction box with dc-dc converter	4
Figure 167-31-10-000_B00	EPSI 570	5
Figure 167-31-10-100_A00	Alpha Electro Electric switch panel	6
Figure 167-31-40-000_A00	Main power controller	7
Figure 167-31-40-150_A00	Bat can communication cable front	8
Figure 167-31-40-200_A00	Bat can communication cable back	9
Figure 167-31-40-250_A00	Junction box communication cable	10
Figure 167-31-40-300_A00	Cooling system cable	11
Figure 167-49-60-100_A00	Alpha Electro Power lever	12
Figure 167-71-00-000_A01	Motor bay general	13

91-00 GENERAL

This chapter contains all of the wiring diagrams that apply to the ALPHA Electro.

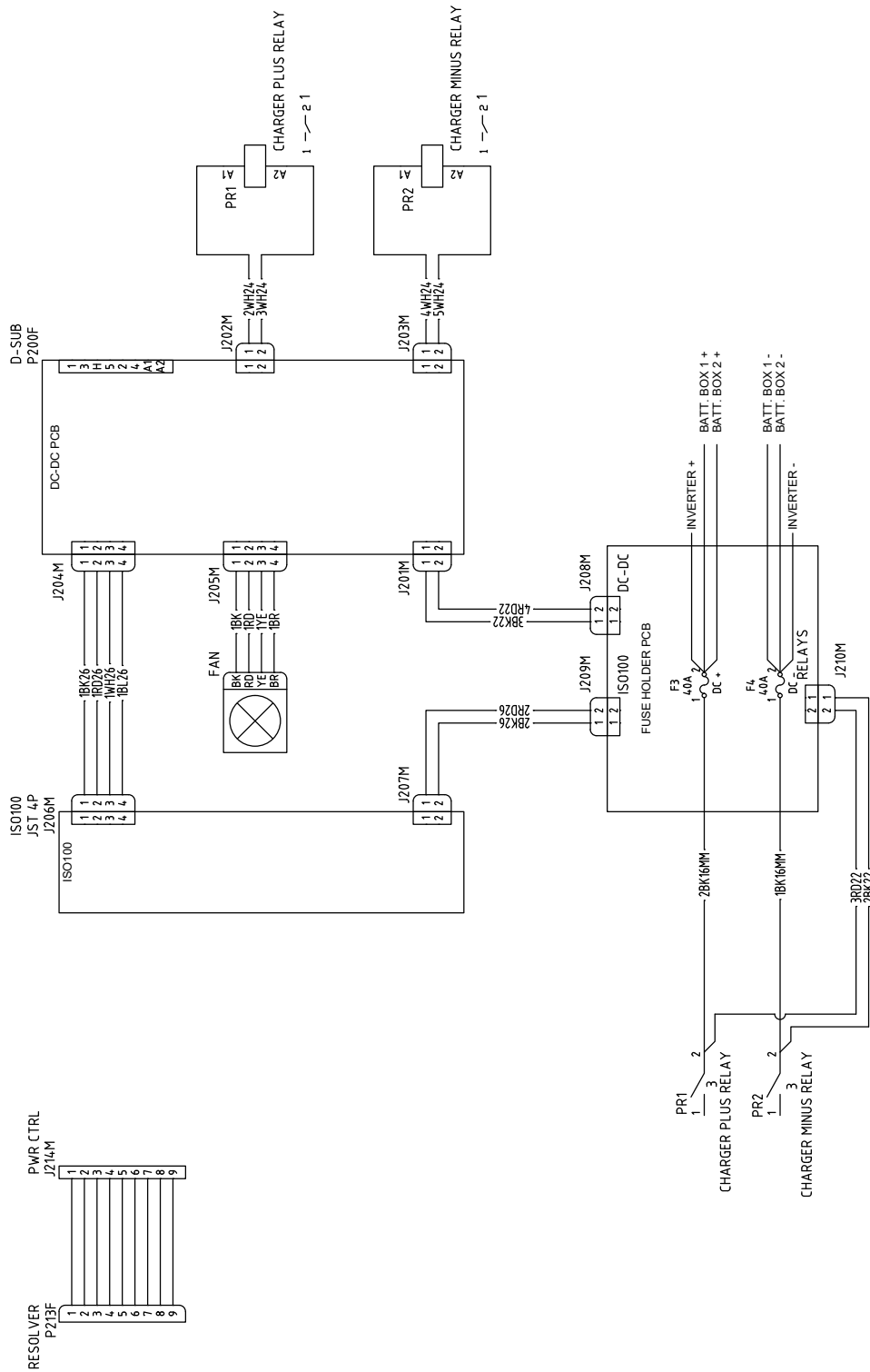

Figure 167-24-60-000_A00
HV junction box with dc-dc converter

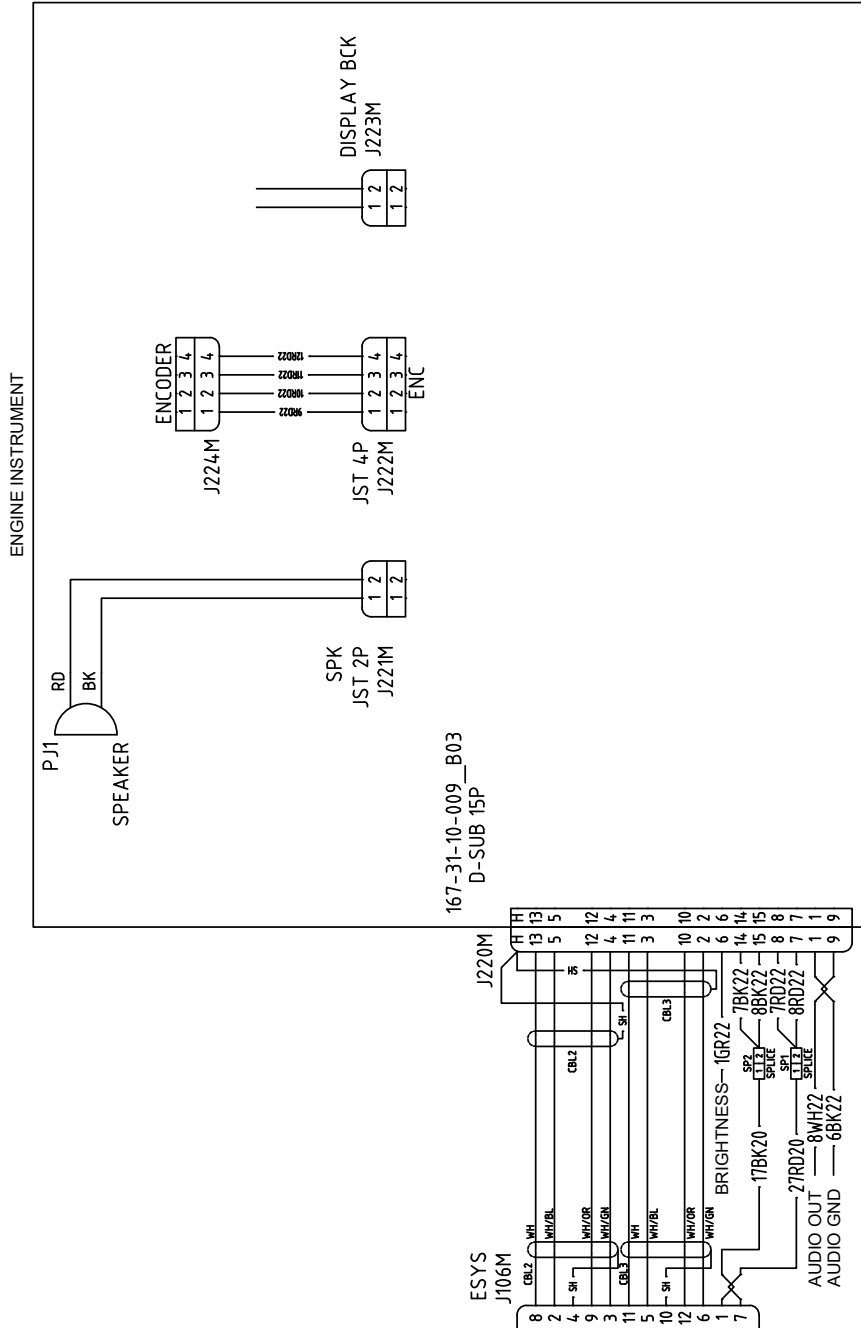

Figure 167-31-10-000_B00
EPSI 570

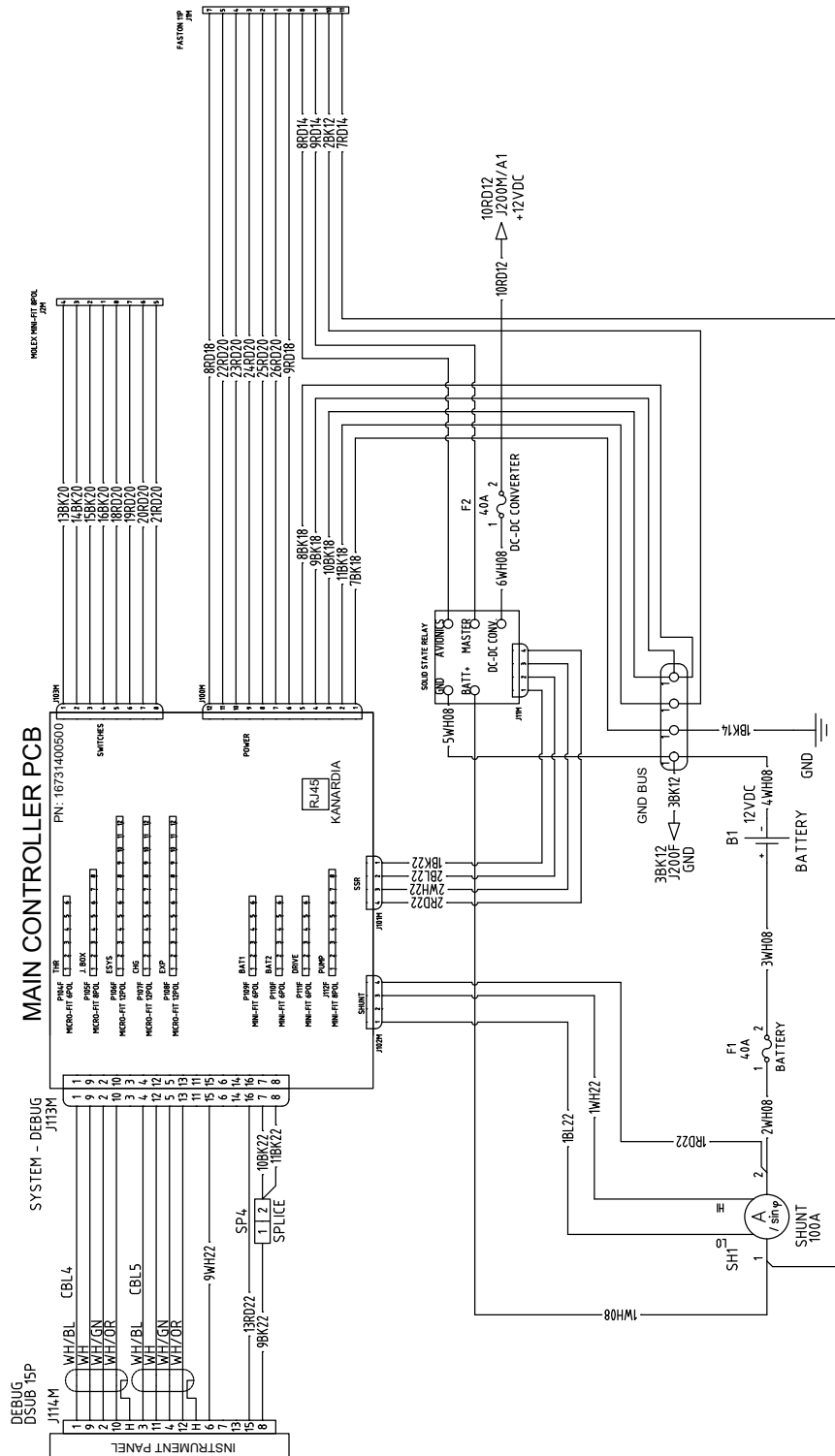

Figure 167-31-40-000_A00
Main power controller

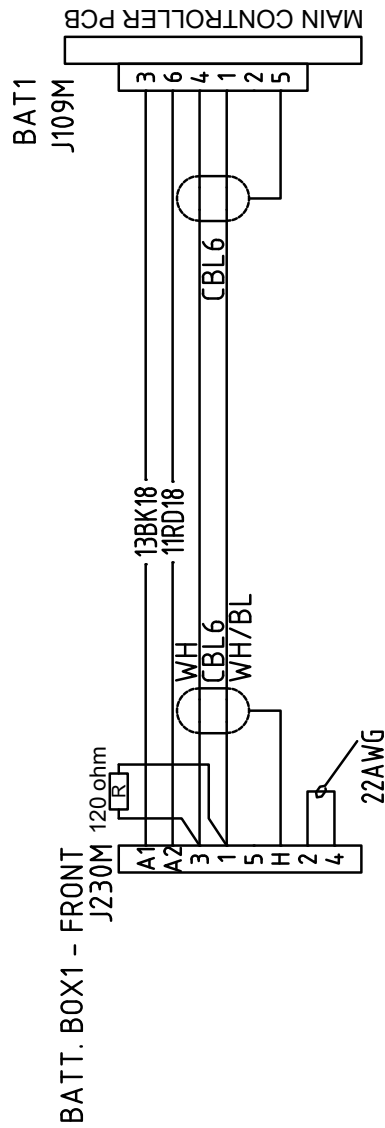

Figure 167-31-40-150_A00
Bat can communication cable front

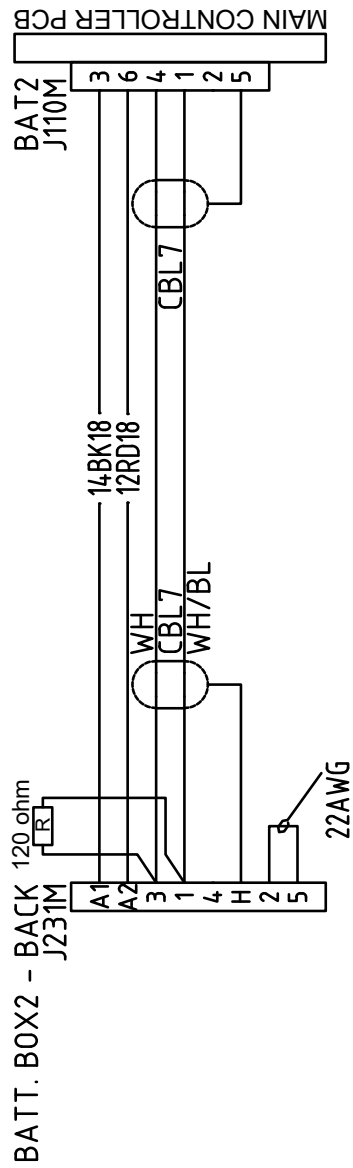

Figure 167-31-40-200_A00
Bat can communication cable back

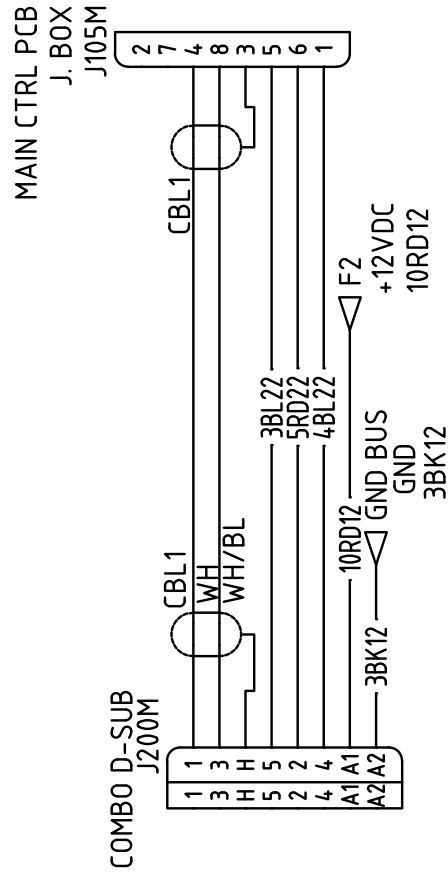

Figure 167-31-40-250_A00
Junction box communication cable

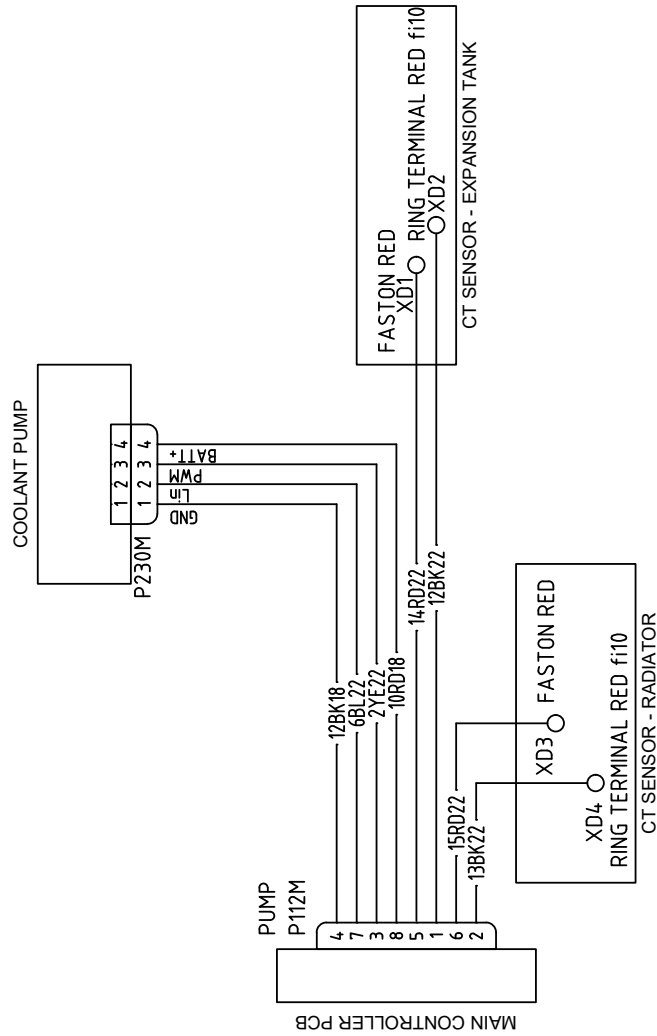

Figure 167-31-40-300_A00
Cooling system cable

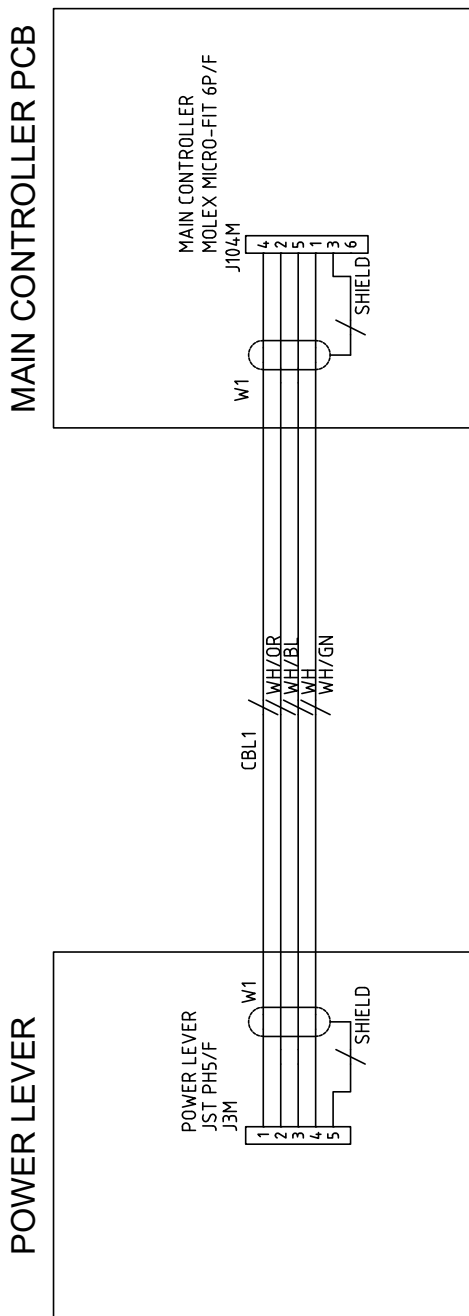

Figure 167-49-60-100_A00
Alpha Electro Power lever

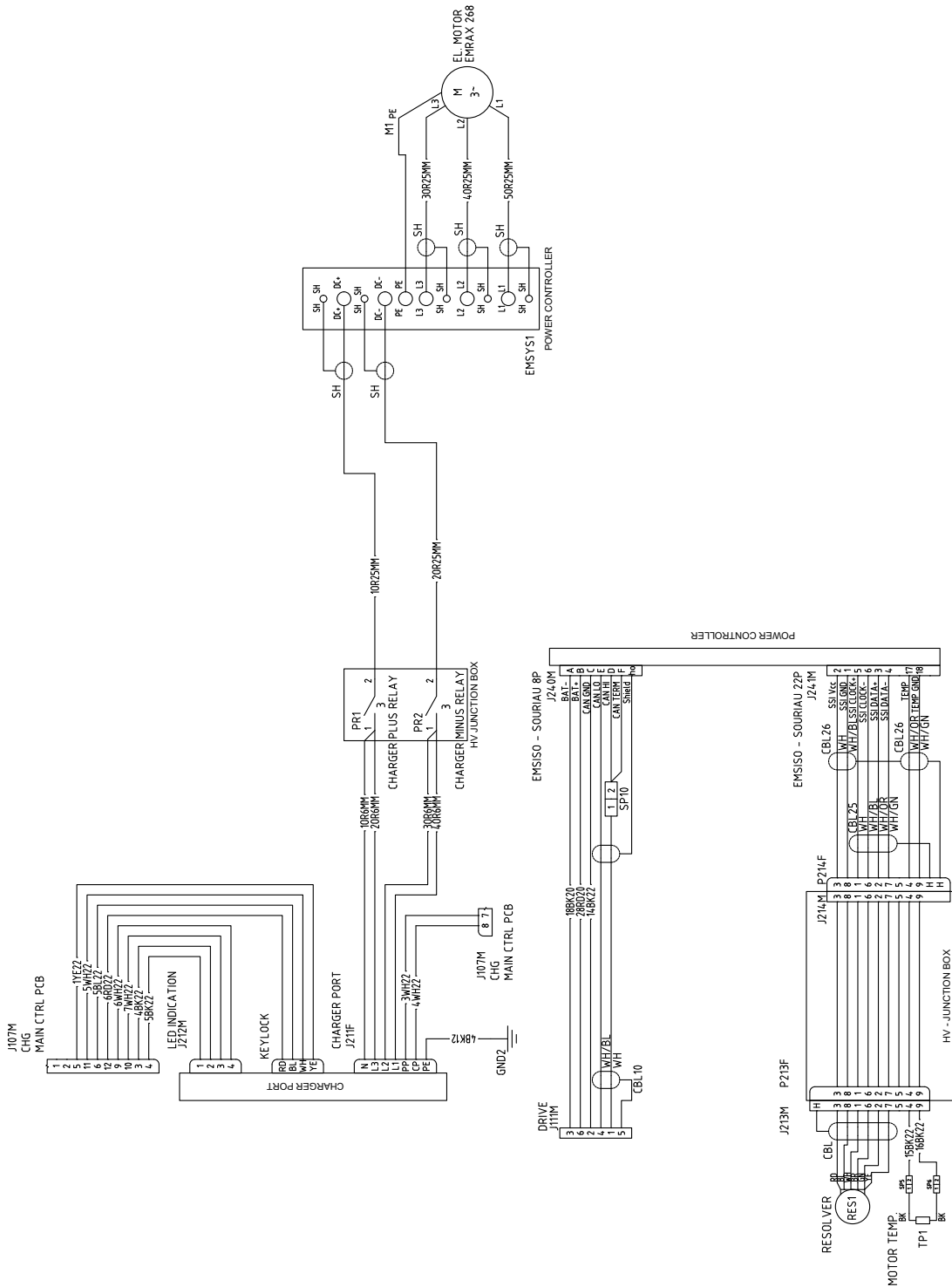

Figure 167-71-00-000_A01
Motor bay general

PIPISTREL

This page is intentionally left blank.

95

CHAPTER 95 – SPECIAL PURPOSE EQUIPMENT

TABLE OF CONTENTS

SECTION	SUBJECT	PAGE NUMBER
95-00	GENERAL Description Maintenance Practices	95-03

95-00 GENERAL

1. Description

This chapter describes the special purpose equipment on the ALPHA Electro. It covers the Galaxy Rescue System GRS 6/473 SD SPEEDY DULV, installed as serial equipment on the ALPHA Electro. The system is not accounted for in the sense of “alternative level of safety”. It is considered a true “second chance” beyond what is required by the certification standard.

The system is placed inside a durable cylinder mounted on the starboard side of the aft battery bay. The parachute, which is stored inside a deployment bag with a rocket motor underneath, is installed in the aforementioned cylinder. Its brand new design presents a canopy that safely opens after 0,4 to 0,7 seconds in distance of 15-18 metres above the aircraft. It is launched in a special deployment bag, which decreases the risk of aircraft debris breaching the canopy. The parachute rescue system is activated manually, by pulling the activation handle mounted on the cabin bulk-head. After being activated, the main canopy opens and fully inflates within 3,2 seconds.

WARNING! The activation handle safety pin should be inserted when the aircraft is parked or hangered to prevent accidental deployment. The safety pin **MUST** be removed before operating the ALPHA Electro.

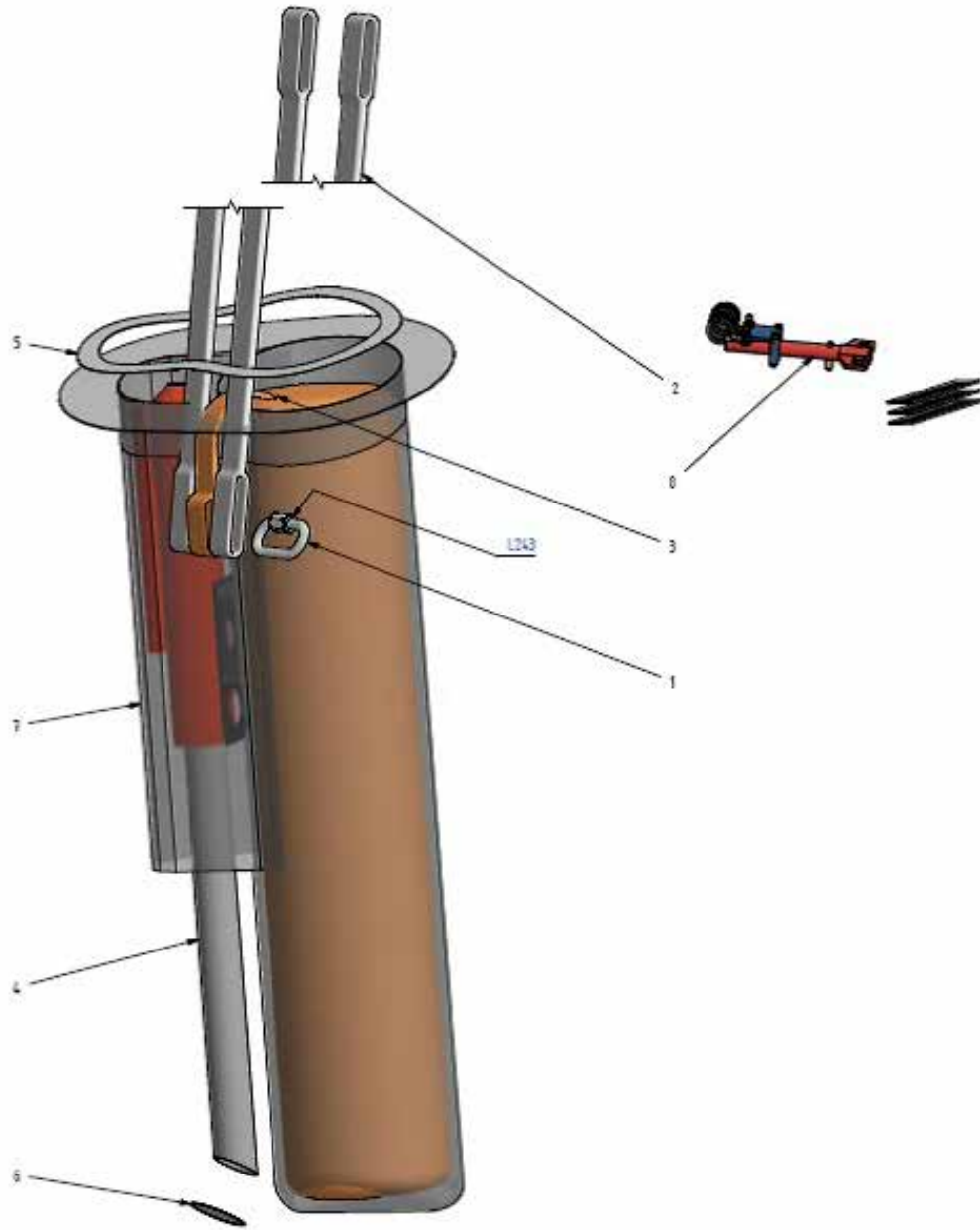

Figure 95-001
GRS rocket charged parachute
rescue system

- | | | | |
|---|-----------------------------|---|---|
| 1 | Carbiner | 5 | Container cover mask |
| 2 | Kevlar belt | 6 | Adhesive label |
| 3 | GRS Rescue system GRS 6-600 | 7 | Parachute container assembly |
| 4 | Rocket blast tube | 8 | Parachute release handle fastening material |

2. Maintenance practices

WARNING: The ALPHA Electro’s rescue system incorporates a ballistic rocket that can cause serious injuries and bodily harm if not dealt with carefully.

WARNING: DO NOT, IN ANY CIRCUMSTANCES, ACTIVATE THE RESCUE SYSTEM ON THE GROUND. People in the vicinity of the aircraft may be injured and the aircraft will be rendered out of service until repaired.

WARNING: Operating the ALPHA Electro is NOT PERMITTED if the rescue system is not in good working condition (i.e. functional). The ALPHA Electro is NOT AIRWORTHY if the rescue system is inoperative.

95-00: 2.1. Activation handle

95-00: 2.1.1. Inspection/check

Reference: Figure 95-001

Step	Action	Required parts, materials and tools	Reference
1	Locate the activation handle in the cabin		
2	Carry out visual inspection of the handle.		05-20
3	Remove the safety pin. Rotate the handle to determine whether it moves unhindered and hasn’t incurred any damage. DO NOT PULL THE HANDLE! JUST LEAVE IT IN ITS HOUSING AND ROTATE IT.		
4	Install the safety pin.		

95-00: 2.2. Rescue system hatch

95-00: 2.2.1. Inspection/check

Step	Action	Required parts, materials and tools	Reference
1	Locate the rescue system hatch on the top of the fuselage, just behind the sunroof.		
2	Carry out visual inspection of the rescue system hatch. Make sure it’s not obstructed by anything.		05-20

95-00
GENERAL

95-00: 2.3. Rocket exhaust hatch

95-00: 2.3.1. Inspection/check

Step	Action	Required parts, materials and tools	Reference
1	Locate the pitot tube fastened to the bottom surface of the starboard wing.		
2	Carry out visual inspection. Make sure the wing's composite structure around the tube's mounting flange hasn't incurred any damage.		05-20

WARNING: The ALPHA Electro's rescue system must be repacked every 6 years and replaced every 30. The repacking date is indicated on the parachute canister. **REMOVAL AND INSTALLATION MUST BE CARRIED OUT FOLLOWING PIPISTREL'S INSTRUCTIONS AND ONLY BY A CERTIFIED AVIATION MECHANIC. ONLY GALAXY HOLDING s.r.o. IS PERMITTED TO REPACK THE RESCUE SYSTEM. ONCE THE SYSTEM IS REMOVED FROM THE AIRCRAFT, IT IS THE OWNER/OPERATOR'S RESPONSIBILITY TO CONTACT GALAXY HODLING s.r.o. AND ARRANGE FOR IT TO BE REPACKED OR REPLACED.**

To get the rescue system repacked, please contact:

GALAXY HOLDING s.r.o.
Třída 1. máje 24a
460 01 Liberec 3
Czech Republic
tel./fax: ++420 48 510 44 92
mobil: ++420 777 55 00 91

NOTE: Refer to PI-167-25-61-002_A00 Parachute Repacking Instructions

To get the rescue system replaced, please contact:

PIPISTREL d.o.o.
GORIŠKA CESTA 50a
SI-5270 AJDOVŠČINA
SLOVENIA
tel.: +386 5 36 63 873
fax.: +386 5 36 61 263

NOTE: Refer to PI-167-25-61-001_A02 Parachute Installation Manual

99

CHAPTER 99 – APPENDICES

TABLE OF CONTENTS

APPENDIX	SUBJECT	PAGE NUMBER
99-A	ASTM F2483 CROSS-REFERENCE CHART	99-03
99-B	VENT/DRAIN HOLE LOCATIONS	99-05
99-C	EPSI 570 SYSTEM DESCRIPTION AND WARNINGS	99-07

APPENDIX 99-A

ASTM F2483-12 CROSS-REFERENCE CHART

ASTM F2483-12	CORRESPONDING CHAPTER IN THIS MANUAL
5.1.1.1	TBD
5.1.1.2	TBD
5.1.1.3	12-40
5.1.1.4	72-00
5.1.1.5	08-10, 08-20
5.1.1.6	12-10
5.1.1.7	12-10
5.1.1.8	20-30
5.1.1.9	INTRO, 04-00, 05-00, 20-00
5.1.1.10	TBD
5.1.2	05-00
5.1.3.1	51-00, 57-00
5.1.3.2	51-00, 55-00
5.1.3.3	32-00
5.1.3.4	51-00, 55-00
5.1.4	72-00
5.1.5	28-00
5.1.6	61-00
5.1.7	21-00
5.1.8	31-00, 34-00
5.1.9	92-00
5.1.10	51-00
5.1.11	04-00
5.1.12	INTRO
5.1.13	TBD

APPENDIX 99-B

VENT/DRAIN HOLE LOCATIONS

1. Two on the bottom surface of the wing at the wing root
2. One at each end of the air brake bay
3. One at each end of the flaperons
4. One at the bottom of the rudder
5. One near the horizontal stabilizer's hinges
6. One on the elevator
7. One on the bottom surface of the fuselage just aft of the undercarriage strut
8. One on the bottom surface of the fuselage near the control sticks

APPENDIX 99-C

EPSI 570 SYSTEM WARNINGS

System or component malfunctions, warnings and errors are shown in the central part of the display when in FLIGHT mode. It is possible to reset the warning and error messages by pressing the knob. The warning and error messages are “descriptive”, and give a basic description of the problem and/or system affected.

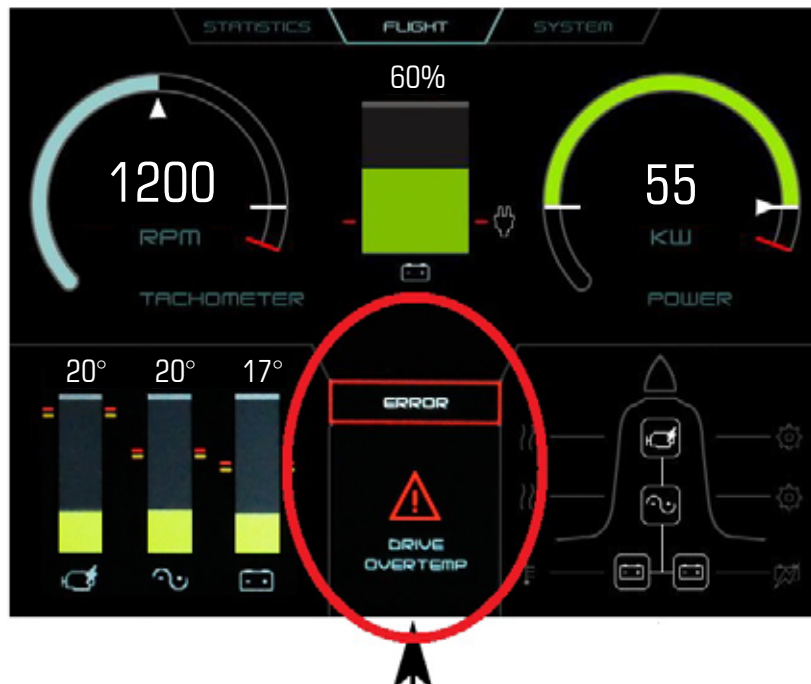

This area of the screen is used to display possible system warnings

Figure 99-C-01
EPSI 570 display

AIRCRAFT	
Warnings	User action
BATTERY 1/2 OVERTEMPERATURE	<ul style="list-style-type: none"> - Reduce power - Monitor battery temperature - Abort mission if necessary
BATTERY SOC < 10%	<ul style="list-style-type: none"> - Throttle idle - Abort mission (battery will disconnect by itself, depends on the cell voltage)

AIRCRAFT	
Errors	Use action
ONLY ONE BATTERY PACK IS ACTIVE	This error appears when power controller is ON and when motor RPM exceeds 300. - Do not take-off
BATTERY 1/2 DISCONNECTED DUE TO [OVERCURRENT WHILE CHARGING, OVERTEMPERATURE, CONNECTOR DISCONNECT, CELL UNVERVOLTAGE, CELL OVERVOLTAGE]	Errors OVERTEMPERATURE, OVERCURRENT WHILE CHARGING and CELL UNDERVOLTAGE only appear while flying. - Reduce power immediately (battery will disconnect by itself)
BATTERY 1/2 STARTUP FAILED CODE: X	This error appears after turning the power enable switch on during ground operation. »X« represents the error number. - Do not take-off - NOTE the number - Report error number to technical support at maintainance@pipistrel.si
DRIVE OVERTEMPERATURE	This error appears when maximum power controller or motor temperature is exceeded. - Reduce power - Monitor temperature - If the temperature doesn't drop abort mission
DRIVE TEMPERATURE SENSOR FAILURE	WARNING!!! The power controller may reduce power to 0 if and when sensor failure happens. - Reduce power - Abort mission
DRIVE COMMUNICATION FAILURE	The error only appears during ground operation. - Abort mission (in this case the start-up is not possible)
COOLANT SENSOR FAILURE	- Reduce power - Abort mission
DC/DC COMMUNICATION FAILURE	- Abort mission
DC/DC MALFUNCTION	- Abort mission
DC/DC NOT WORKING	This error appears when motor RPM exceeds 300. - Abort mission
POWER LEVER COMMUNICATION FAILURE	When this error appears the power setting will stay on the last value. - Look for somewhere to land - As soon as the landing spot is within the glide cone, pull out the PWR CTRL circuit breaker and land
DRIVE AUX POWER FAILURE	When this error appears, the motor and power controller don't have power. This error only appears during ground operation. - Abort mission
PUMP AUX POWER FAILURE	This error indicates water pump failure and only appears during ground operation. - Abort mission

PIPISTREL®

Pipistrel d.o.o.
Goriška cesta 50a
SI-5270 Ajdovščina
Slovenija - EU

t +386 (0)5 3663 873
f +386 (0)5 3661 263
info@pipistrel-aircraft.com
www.pipistrel-aircraft.com

Pipistrel Italia
Via Fratelli Rusjan, 26
34070 Savogna d'Isonzo (GO)
Italia - EU

t +39 0481 522000
f +39 0481 522110
pipistrel@legalmail.it
www.pipistrel-aircraft.com

Pipistrel Vertical Solutions d.o.o.
Vipavska cesta 2
SI-5270 Ajdovščina
Slovenija - EU

t +386 5 366 38 73
f +386 5 366 12 63
info@pipistrel-aircraft.com
www.pipistrel-aircraft.com